

SM

Expansion Tanks



In pressure boosting systems

The accumulator vessel with replaceable bladder is a device that, when fitted into a pressurised water system will provide system water at a pre-set, sustained pressure.

Its most common application is to supply systems in which the main supply pressure is too low and a pump is fitted to boost the pressure to an acceptable level. As system demands take place the accumulator vessel will sustain system pressure by feeding additional water into the system at the required pressure. This process will limit the number of times the pump needs to start (pump hunting) in order that system pressure remains at the optimum level.

The process is achieved by the addition of a pre-charged gas (usually air or nitrogen) cushion at higher than atmospheric pressure within the vessel shell. This pre-charged cushion is stored between the water bladder and the inner surface of the tank. Any water pressure rise (pumping) causes the cushion to be additionally compressed. As system demands arise, the gas cushion forces the water from the bladder into the system thus maintaining optimum system pressure.

As the retained pressure finally exhausts and system pressure falls, a pressure switch will turn the pump on, re-pressurising the system and the accumulator ready for further use. This way the accumulator will prevent the need for the pump to start every time there is a demand on the water system and will flatten the system pressure curve at the optimum pressure.

In closed heating and cooling circuits

Expansion tanks are devices designed to absorb the volume change of water or some other liquids, thus allowing the correct operation of a heating plant during all its operative phases.

Expansion tanks are composed by a tank in sheet steel and a bladder in synthetic material which separates the heating circuit from a chamber previously charged with air.

Features of accumulator vessels

Accumulators with replaceable bladder are manufactured from the highest quality UNI standard steel plate and welded using certified materials and procedures. The version come in capacities ranging from 8 to 5000 litres. All the models have been designed to hold potable (drinking) water and feature specific technical options to prevent the liquid from coming in contact with the inner surface of the tank.

Expansion tanks are equipped with bladders in special rubber against heat and ageing which are resistant up to 110°C; they are previously charged at a pressure of 4 bars for easy adaptation to the static height of the water column.

Once the construction has been completed, all the models are subjected to a hydraulic test with a pressure of 1.5 times higher than the designed one.

The SM series replaceable bladder accumulators provide a response to the problems of installation in large capacity systems that up until today required either the use of standard accumulators without bladder or the installation of a series of small-sized tanks.

Installing SM series tanks considerably cuts down both installation and maintenance costs.

The SM series come in models with a 8 to 5000 litres capacity thanks to a truly exclusive bladder design.

Supplied in 10 bars and 16 bars versions. Additionally, tailor-made configurations and horizontal versions are available upon request.

Characteristics:

- Sturdy construction in prime quality, long life steel. Complete separation between water and air;
- No contact between water and the inner surface of the tank; Non toxic replaceable bladder for alimentary use.
- Working temperatures: -10° + + 110°C.
- In compliance with essential safety requirements of directive 97/23/EC.
- CE marking.

SM

Expansion Tanks

Accumulator Vessel with Replaceable Bladder

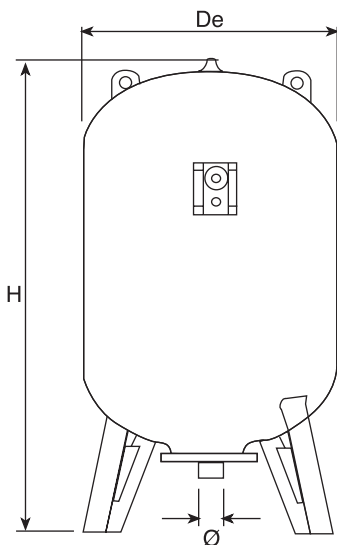

Model	Capacity Litres	De mm	H mm	Ø	Max. Working Pressure (bar)	Precharged Gas Pressure (bar)
SM 8	8	220	380	1"	10/16	4
SM12	12	220	420	1"	10/16	4
SM 19	19	280	420	1"	10/16	4
SM24	24	280	470	1"	10/16	4
SM 35	35	354	400	1"	10/16	4
SM 50	50	409	480	1"	10/16	4
SM 60	60	409	660	1"	10/16	4
SM 80	80	480	840	1"	10/16	4
SM 100	100	480	960	1"	10/16	4
SM 200	200	634	980	1¼"	10/16	4
SM 300	300	634	1230	1¼"	10/16	4
SM 500	500	740	1550	1¼"	10	4
SM 500	500	740	1550	1¼"	16	4
SM 750	750	740	1950	2"	10	4
SM 750	750	800	1950	2½"	16	4
SM 1000	1000	800	2200	2½"	10/16	4
SM 1500	1500	960	2400	2½"	10/16	4
SM 2000	2000	1100	2500	2½"	10/16	4
SM 3000	3000	1200	2800	3"	10/16	4
SM 4000	4000	1450	3100	3"	10/16	4
SM 5000	5000	1450	3350	3"	10/16	4

General formula to size bladder-equipped accumulators:

$$V_t = 16,5 \times \frac{Q_{\max}}{A} \times \frac{P_s \times P_a}{P_s - P_a} \times \frac{1}{P_p}$$

V_t = Accumulator global volume [litres]

Q_{\max} = Pump max. delivery capacity or system maximum consumption [lt/min]

A = Number of pump starts - stops per hour (12...15)

P_s = Pump stop (absolute) pressure [bar]

P_a = Pump starting (absolute) pressure [bar]

P_p = (absolute) precharge pressure ($P_a - 0.5$) [bar]

The accumulator may be sized according to two different techniques:

Sizing the accumulator by using the pump maximum delivery capacity

- Replace Q_{\max} in the formula by the pump delivery capacity.
- The P_a pump starting pressure must be higher than the P_p precharge pressure.

- In order to optimise the accumulator yielding, the precharge pressure must be 0.5 bars lower than the pump starting pressure.

Sizing the accumulator by using the maximum consumption of the system:

In that case, define the maximum consumption of users by applying the calculation method in accordance with UNI 9182;

- Identify types of users (shower, WC, sink, etc.) equipped on the system; assess the number of users for each type;
- Refer to table 1, calculate the number of total system charge units (CU) by multiplying each type of user by the corresponding CU listed in the table;
- Once the total charge units have been computed, turn them into litres per minute by referring to table 2.

Once the system maximum consumption (Q_{\max}) has been defined, proceed to size the accumulator by applying the above formula.

SM

Expansion Tanks

Sizing of a Bladder Accumulator

USER	CU
Wash-basin	2
Bidet	2
Bath	4
Shower	4
Toilet bowl	5
Push button bowl	10
Kitchen sink	4
Sink	3
Feet wash-basin	2
Drinking fountain	0.75
3/8" hydrant	2
1/2" hydrant	4
3/4" hydrant	6
1" hydrant	10

The expansion tank's useful volume must be calculated according to a maximum working pressure (pe), corresponding to the safety valve's adjustment pressure, diminished by a quantity equal to the difference value between the expansion tank and the safety valve, if the latter is situated downwards, otherwise increased if the safety valve is located upwards. The expansion tank's useful volume must correspond to the expansion volume (Ve), in practice the maximum change of the water volume which can occur in the plant is the following one:

$$V_e = C \times (u_2 - u_1) \text{ [litres]}$$

where:

u₂ = water specific volume at the maximum operative temperature litres/kg.

u₁ = water specific volume at the minimum operative temperature litres/kg.

C = plant's total capacity (boiler, pipes, charges, etc.) kg.

The V_t total volume of the closed expansion tank with a bladder is calculated according to the following formula:

$$V_t = \frac{V_e}{1 - \frac{P_p}{P_e}} \text{ [litres]}$$

where:

V_e = plant's expansion volume litres

P_p = precharge pressure of the expansion tank bar (absolute pressure)

P_e = plant's maximum working pressure or adjustment pressure of the safety valve bar (absolute pressure)

The precharge pressure must correspond to the hydrostatic pressure in the tank's installation place, whereas the difference between the cut in pressure of the safety valve (pv) and the working pressure (pe) is usually 10% of the cut in pressure. A tolerance of 10% of the plant's total volume is allowed in the choice of the tank to be installed.

CONVERSION TABLE (Litres/min.)					
UC	Q [lt/min]	UC	Q [lt/min]	UC	Q [lt/min]
6	18	100	189	1250	930
8	24	120	219	1500	1050
10	30	140	234	1750	1128
12	36	160	255	2000	1230
14	40.8	180	276	2250	1320
16	46.8	200	297	2500	1410
18	51	225	321	2750	1470
20	55.8	250	345	3000	1560
25	67.8	275	366	3500	1680
30	78	300	387	4000	1830
35	87.6	400	468	4500	1950
40	97.2	500	540	5000	2070
50	114	600	600	6000	2280
60	132	700	660	7000	2460
70	144	800	714	8000	2640
80	159	900	774	9000	2820
90	174	1000	828	10000	3000

T °C	u litres/Kg	T °C	u litres/Kg
-10	100,186	36	100,632
-5	100,070	38	100,706
0	100,013	40	10,078
2	100,003	45	10,099
4	100,000	50	10,121
6	100,003	55	10,145
8	100,012	60	10,171
10	100,027	65	10,198
12	100,048	70	10,227
14	100,073	75	10,258
16	100,103	80	10,290
18	100,138	85	10,324
20	100,177	90	10,359
22	100,221	95	10,396
24	100,268	100	10,434
26	100,320	110	10,515
28	100,375	120	10,600
30	100,435	130	10,795
32	100,497	140	10,795
34	100,563	150	10,903

SM

Expansion Tanks

Expansion Tanks for Packaged Units

Replaceable bladder
Bladder material= EPDM
Comply to CE norms

According to directive PED 97/23/CE Replaceable EPDM Membrane
Operating Temperature = -10°C /+100°C
Precharged Pressure = 3 bar



Tank Type	Model Name	Operating Pressure (bar)	Height (mm)	Diameter (mm)	Connection	Packing Size (mm)	
Vertical	SM-V 8/10	10	320	Ø220	1"	23x23x32	carton box
Vertical	SM-V 8/16	16	320	Ø220	1"	23x23x32	carton box
Vertical	SM-V 8/25	25	325	Ø220	1"	23x23x33	carton box
Vertical	SM-V 12/10	10	450	Ø220	1"	23x23x46	carton box
Vertical	SM-V 12/16	16	450	Ø220	1"	23x23x46	carton box
Vertical	SM-V 19/10	10	410	Ø260	1"	27x27x43	carton box
Vertical	SM-V 19/16	16	410	Ø260	1"	27x27x43	carton box
Oval	SM-O 24/10	10	325	Ø360	1"	36x36x33	carton box
Vertical	SM-V 24/10	10	470	Ø280	1"	28x28x47	carton box
Vertical	SM-V 24/16	16	470	Ø280	1"	28x28x47	carton box
Vertical	SM-V 24/25	25	470	Ø260	1"	26x26x47	carton box
Vertical	SM-V 35/10	10	470	Ø380	1"	38x38x47	carton box

DESIGN PRESSURE	10 BAR
TEST PRESSURE	15 BAR
PRE-CHARGE PRE.	3 BAR
DESIGN TEMPERATURE	-10 / +100 °C
PAINTE FEATURES	ELEKTROSTATIK DUST PAINT EPOXY POLYS. - RAL 3000 (MIN. 70 MICRON)

NO	DESCRIPTION	MATERIAL
1	NIPPEL	SI 37
2	UNDER DISH	6224- EN10111
3	UPPER DISH	6224- EN10111
4	VALVE	S235JR
5	MEMBRANE	EPDM
6	VALVE CAP	POLIPROPILEN
7	FLANGE	S235JRG2 - EN10025

8 LT VERTICAL
CLOSED EXPANSION VESSEL

PROJECT NO
SMV 8/10

SM

Expansion Tanks

Expansion Tanks for Packaged Units

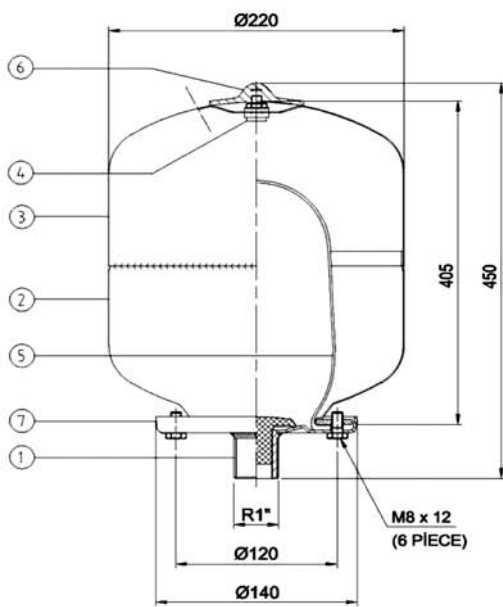

DESIGN PRESSURE	10 BAR
TEST PRESSURE	15 BAR
PRE-CHARGE PRE.	3 BAR
DESIGN TEMPERATURE	-10 / +100 °C
PAINT FEATURES	ELEKTROSTATIK DUST PAINT EPOXY POLYS. - RAL 3000 (MIN. 70 MIKRON)

NO	DESCRIPTION	MATERIAL
1	NIPPEL	St 37
2	UNDER DISH	6224- EN10111
3	UPPER DISH	6224- EN10111
4	VALVE	S235JR
5	MEMBRANE	EPDM
6	VALVE CAP	POLIPROPILEN
7	FLANGE	S235JRG2 - EN10025

12 LT VERTICAL
CLOSED EXPANSION VESSEL



PROJECT NO
SMV 12/10

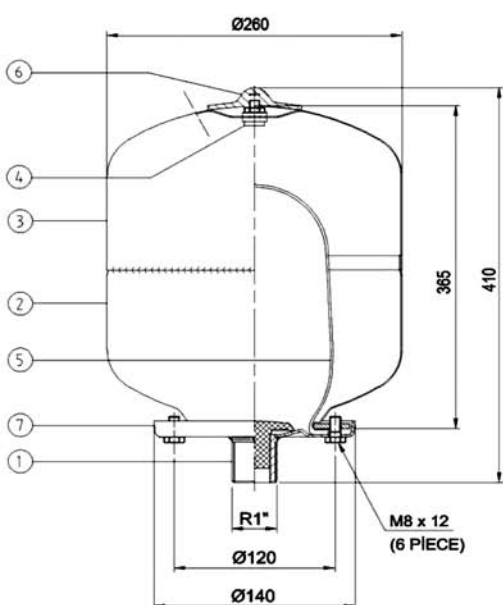

DESIGN PRESSURE	10 BAR
TEST PRESSURE	15 BAR
PRE-CHARGE PRE.	3 BAR
DESIGN TEMPERATURE	-10 / +100 °C
PAINT FEATURES	ELEKTROSTATIK DUST PAINT EPOXY POLYS. - RAL 3000 (MIN. 70 MIKRON)

NO	DESCRIPTION	MATERIAL
1	NIPPEL	St 37
2	UNDER DISH	6224- EN10111
3	UPPER DISH	6224- EN10111
4	VALVE	S235JR
5	MEMBRANE	EPDM
6	VALVE CAP	POLIPROPILEN
7	FLANGE	S235JRG2 - EN10025

19 LT VERTICAL
CLOSED EXPANSION VESSEL



PROJECT NO
SMV 19/10

SM

Expansion Tanks

Expansion Tanks for Packaged Units

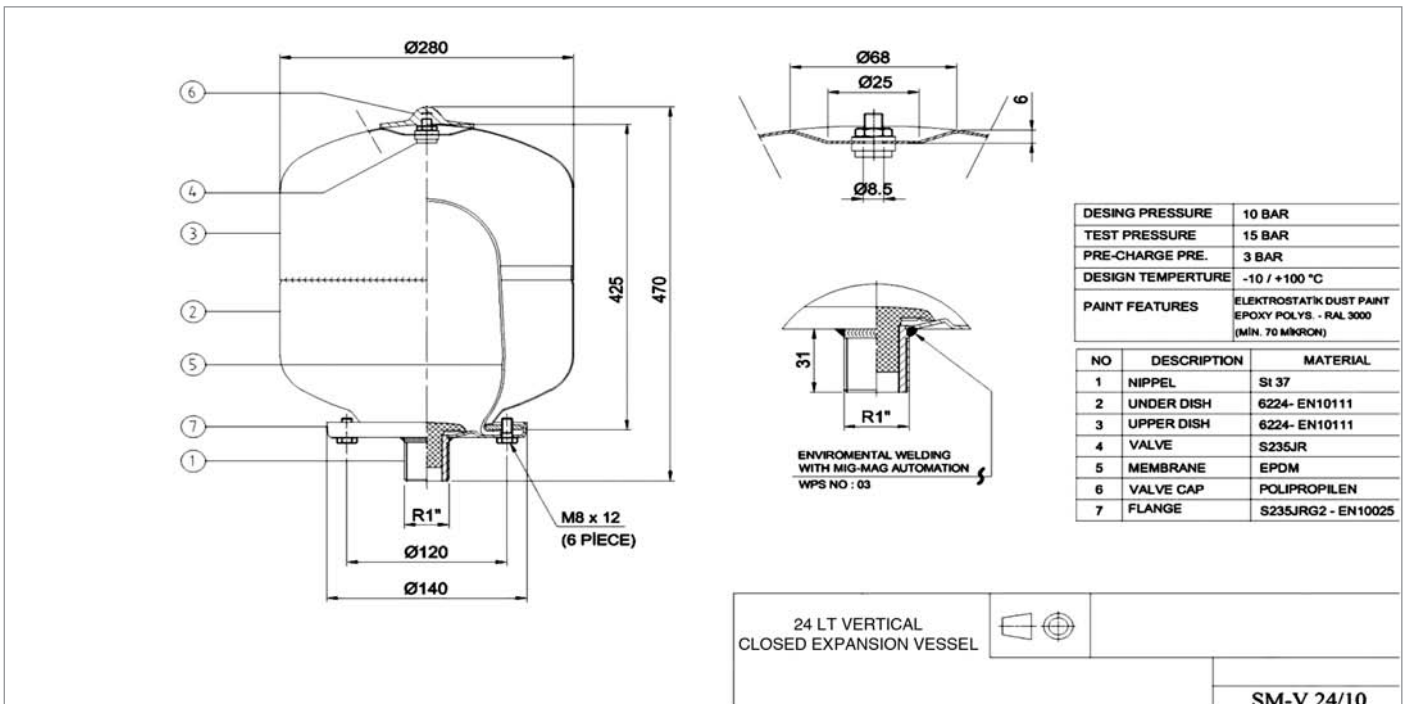
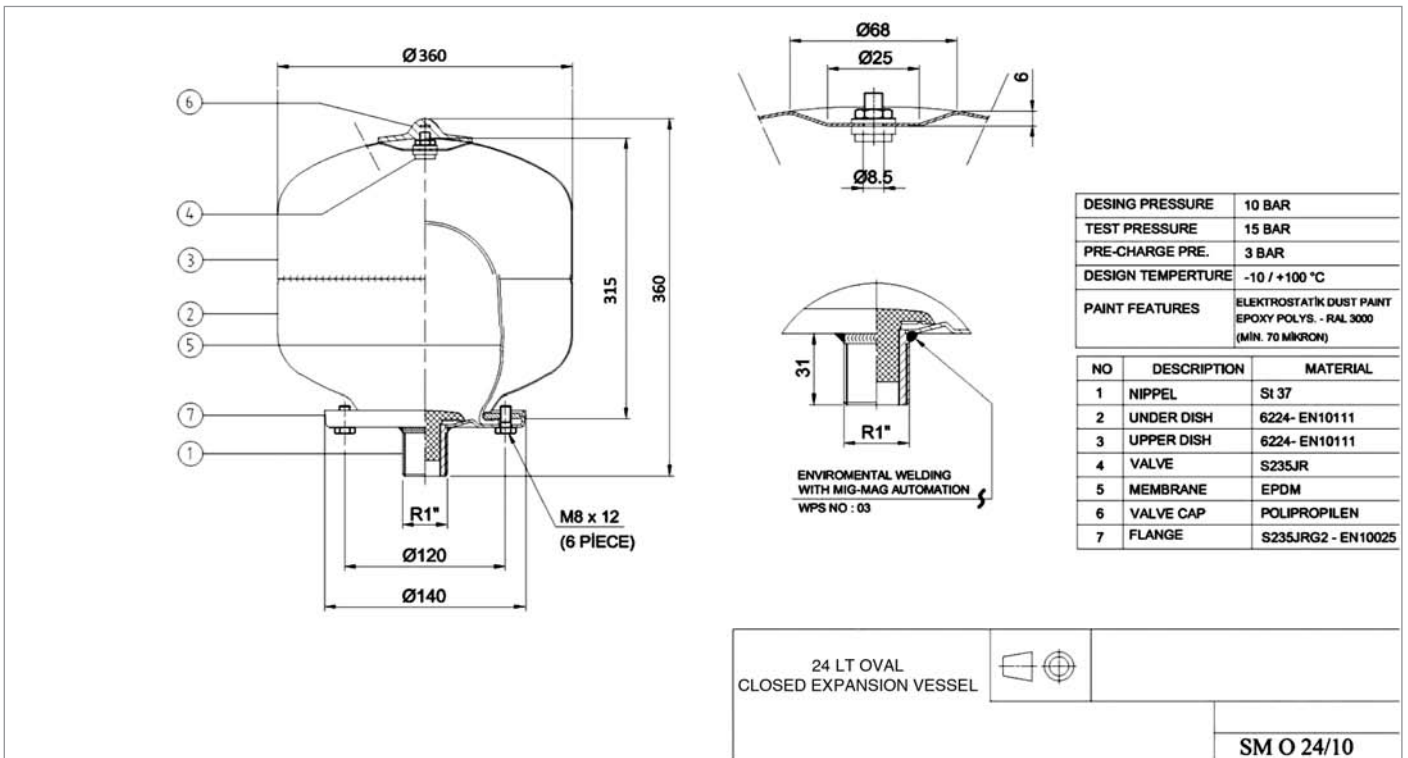

SM

Expansion Tanks

Expansion Tanks for Packaged Units

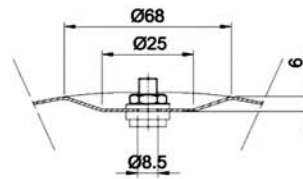
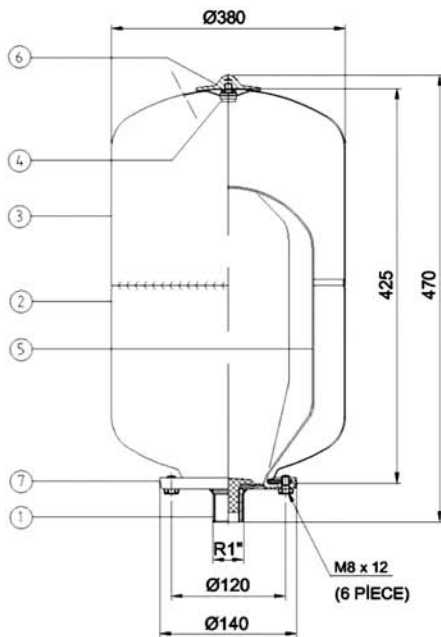

DESIGN PRESSURE	10 BAR
TEST PRESSURE	15 BAR
PRE-CHARGE PRE.	3 BAR
DESIGN TEMPERATURE	-10 / +100 °C
PAINT FEATURES	ELEKTROSTATIK DUST PAINT EPOXY POLYS. - RAL 3000 (MIN. 70 MIKRON)

NO	DESCRIPTION	MATERIAL
1	NIPPEL	St 37
2	UNDER DISH	6224- EN10111
3	UPPER DISH	6224- EN10111
4	VALVE	S235JR
5	MEMBRANE	EPDM
6	VALVE CAP	POLIPROPILEN
7	FLANGE	S235JRG2 - EN10025

35 LT VERTICAL CLOSED EXPANSION VESSEL		
		SM-V 35/10

SM

Expansion Tanks

Horizontal Expansion Tanks

According to Directive PED 97/23/CE
 Replaceable EPDM Membrane
 Operating Temperature = -10°C / +100°C
 Operating Pressure = 10 bar
 Precharged Pressure = 1,5 bar



Tank Type	Model Name	Height (mm)	Diameter (mm)	Connection	Packing Size (mm)	
Horizontal	SMH 24/10	470	280	1"	29x47x32	carton box
Horizontal	SMH-INOX 24/10	490	325	1"	38x62x43	carton box
Horizontal	SMH 50/10	620	380	1"	38x62x43	carton box
Horizontal	SMH 60/10	670	380	1"	38x67x43	carton box
Horizontal	SMH 80/10	720	430	1"	43x72x47	carton box
Horizontal	SMH 100/10	800	460	1"	46x80x54	carton box

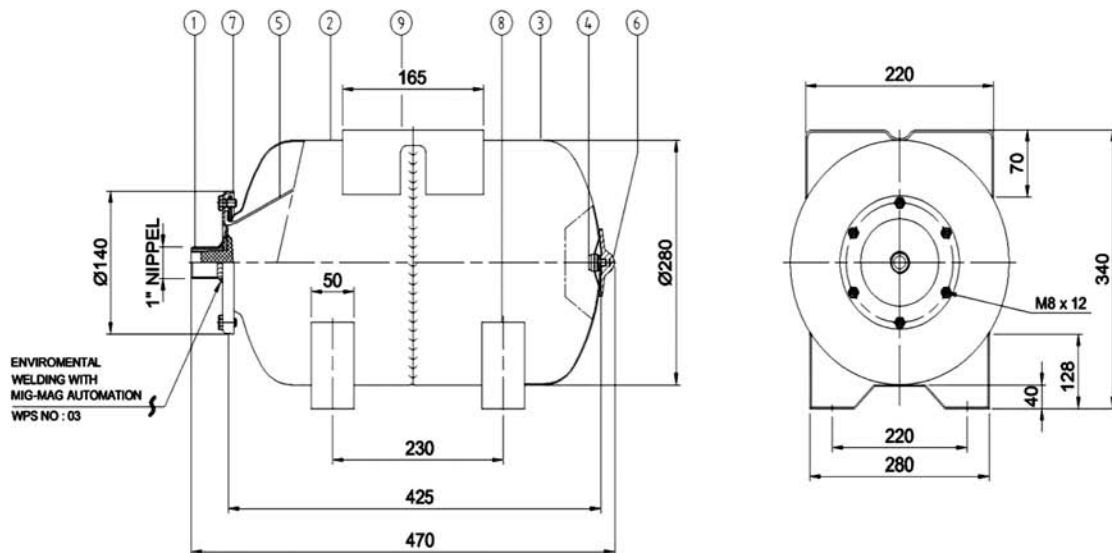

NO	DESCRIPTION	MATERIAL
1	NIPPEL	St 37
2	UNDER DISH	6224- EN10111
3	UPPER DISH	6224- EN10111
4	VALVE	S235JR
5	MEMBRANE	EPDM
6	VALVE CAP	POLIPROPILEN
7	FLANGE	S235JRG2 - EN10025
8	FOOT	S235JRG2 - EN10025
9	BASE	S235JRG2 - EN10025

DESIGN PRESSURE	10 BAR
TEST PRESSURE	15 BAR
PRE-CHARGE PRE.	3 BAR
DESIGN TEMPERATURE	-10 / +100 °C
PAINT FEATURES	ELEKTROSTATIK DUST PAINT EPOXY POLYS. - RAL 3000 (MIN. 70 MICRON)

24 LT HORIZONTAL
CLOSED EXPANSION VESSEL



SM-H 24/10

SM

Expansion Tanks

Vertical Expansion Tanks - 10 Bar

According to Directive PED 97/23/CE
 Replaceable EPDM Membrane
 Operating Temperature = -10°C / +100°C
 Operating Pressure = 10 bar
 Precharged Pressure = 4 bar



Tank Type	Model Name	Height (mm)	Diameter (mm)	Connection	Packing Size (mm)	
Vertical	SM 50/10	750	380	1"	38x38x75	carton box
Vertical	SM 60/10	810	380	1"	38x38x82	carton box
Vertical	SM 80/10	960	430	1"	43x43x96	carton box
Vertical	SM 100/10	990	460	1"	46x46x99	carton box
Vertical	SM 200/10	1120	590	1¼"	55x55	pallet
Vertical	SM 300/10	1230	640	1¼"	59x59	pallet
Vertical	SM 500/10	1550	750	1¼"	69x69	pallet
Vertical	SM 750/10	1950	750	2"	69x69	pallet
Vertical	SM 1000/10	2180	800	2"	76x76	pallet
Vertical	SM 1500/10	2380	960	2"	90x90	pallet
Vertical	SM 2000/10	2520	1100	2"	100x100	pallet
Vertical	SM 3000/10	2800	1200	2½"	110x110	pallet
Vertical	SM 4000/10	3100	1450	3"	100x200	pallet
Vertical	SM 5000/10	3720	1450	3"	100x200	pallet

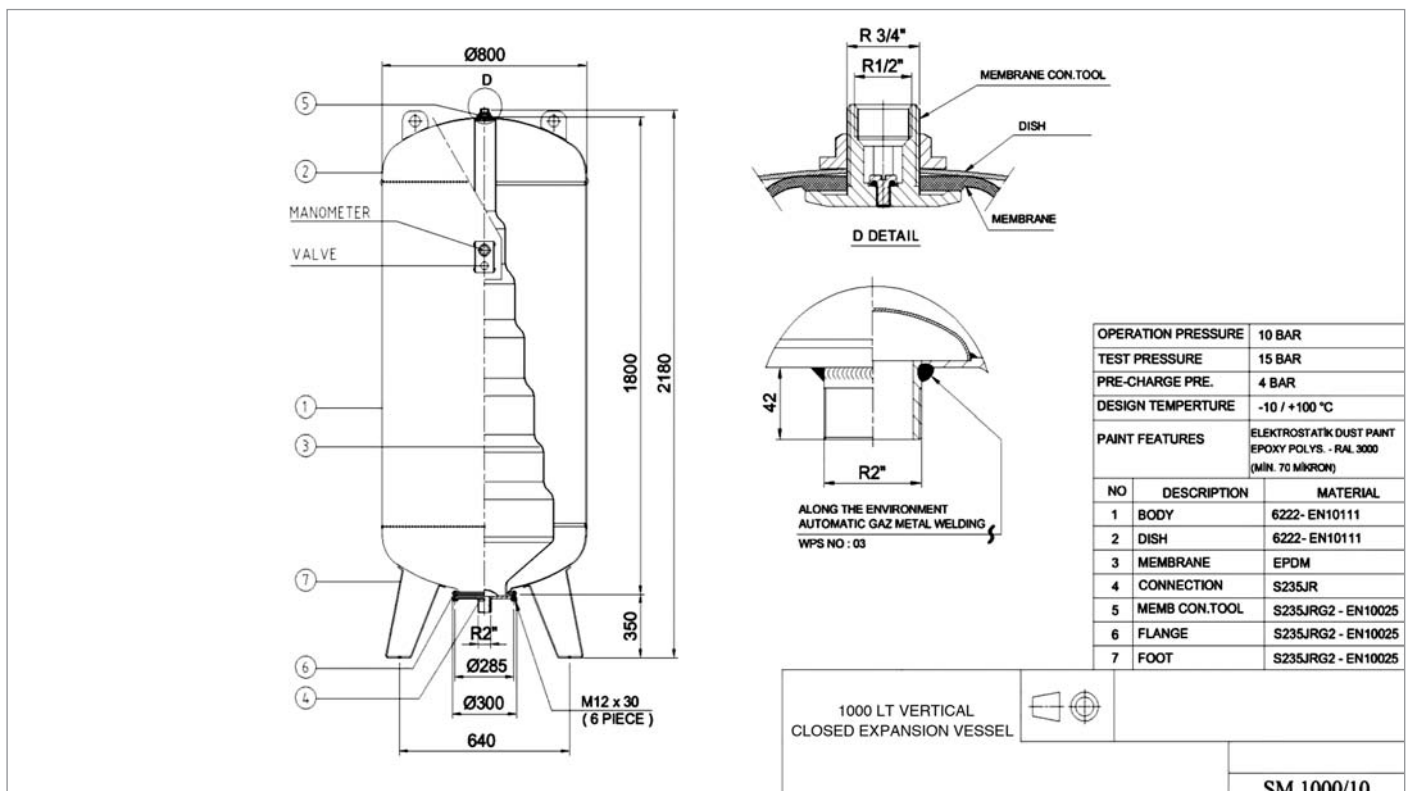

SM

Expansion Tanks

Vertical Expansion Tanks - 16 Bar

According to Directive PED 97/23/CE
 Replaceable EPDM Membrane
 Operating Temperature = -10°C / +100°C
 Operating Pressure = 16 bar
 Precharged Pressure = 4 bar



Tank Type	Model Name	Height (mm)	Diameter (mm)	Connection	Packing Size (mm)	
Vertical	SM 50/16	750	380	1"	38x38x75	carton box
Vertical	SM 100/16	990	460	1"	46x46x99	carton box
Vertical	SM 200/16	1120	590	1¼"	55x55	pallet
Vertical	SM 300/16	1230	640	1¼"	59x59	pallet
Vertical	SM 500/16	1550	750	1¼"	69x69	pallet
Vertical	SM 750/16	1850	800	2"	69x69	pallet
Vertical	SM 1000/16	2180	800	2"	76x76	pallet
Vertical	SM 1500/16	2380	960	2"	90x90	pallet
Vertical	SM 2000/16	2520	1100	2"	100x100	pallet
Vertical	SM 3000/16	2800	1200	2¼"	110x110	pallet
Vertical	SM 4000/16	3100	1450	3"	100x200	pallet
Vertical	SM 5000/16	3720	1450	3"	100x200	pallet

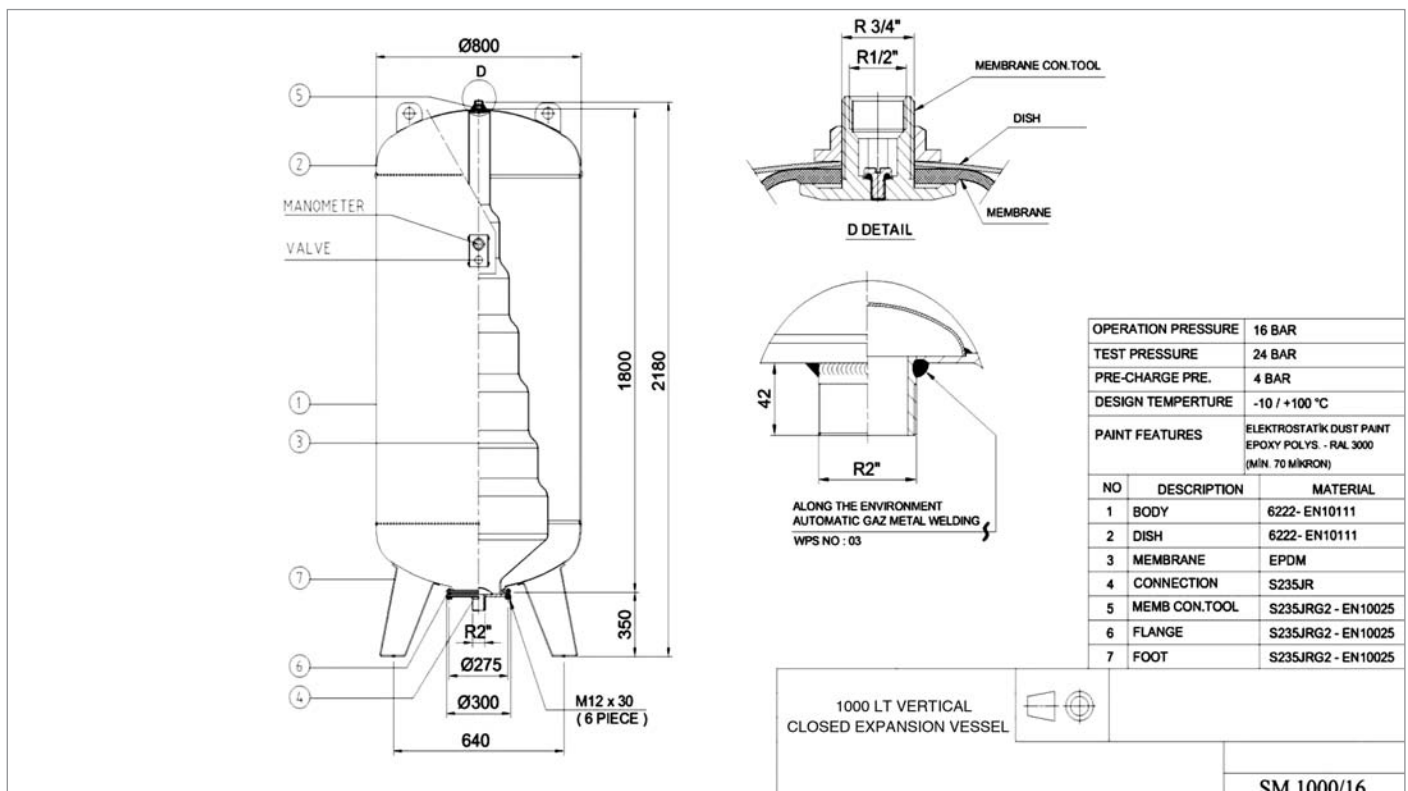

SM

Expansion Tanks

Vertical Expansion Tanks - 25 Bar

According to Directive PED 97/23/CE
 Replaceable EPDM Membrane
 Operating Temperature = -10°C / +100°C
 Operating Pressure = 25 bar
 Precharged Pressure = 4 bar



Tank Type	Model Name	Height (mm)	Diameter (mm)	Connection	Packing Size (mm)	
Vertical	SM 100/25	990	450	1"	46x46x99	carton box
Vertical	SM 200/25	1120	600	1 1/4"	55x55	pallet
Vertical	SM 300/25	1230	640	1 1/4"	59x59	pallet
Vertical	SM 500/25	1550	750	1 1/4"	69x69	pallet
Vertical	SM 750/25	1850	800	2"	69x69	pallet
Vertical	SM 1000/25	2180	800	2"	76x76	pallet
Vertical	SM 1500/25	2380	960	2"	90x90	pallet

DESIGN PRESSURE	25 BAR
TEST PRESSURE	37.5 BAR
PRE-CHARGE PRE.	4 BAR
DESIGN TEMPERATURE	-10 / +100 °C
PAINT FEATURES	ELEKTROSTATIK DUST PAINT EPOXY POLYS. - RAL 3000 (MIN. 70 MIKRON)

NO	DESCRIPTION	MATERIAL
1	BODY	6222- EN10111
2	DISH	6222- EN10111
3	MEMBRANE	EPDM
4	CONNECTION	S235JR
5	MEMB CON.TOOL	S235JRG2 - EN10025
6	FLANGE	S235JRG2 - EN10025
7	FOOT	S235JRG2 - EN10025

500 LT VERTICAL CLOSED EXPANSION VESSEL

SM 500/25

SM

Expansion Tanks

Replaceable Membranes - EPDM



Rubber Material	Height (mm)	Usable For Models	With hole for tie beam
EPDM	248	SM 24	
EPDM	315	SM 35 / SM 50	
EPDM	315	SM 60	
EPDM	700	SM 80 / SM 100	x
EPDM	750	SM 150	x
EPDM	800	SM 200	x
EPDM	1000	SM 300	x
EPDM	1400	SM 500	x
EPDM	1600	SM 750	x
EPDM	2000	SM 1000	x
EPDM	2000	SM 1500	x
EPDM	2000	SM 2000	x
BUTYL	2515	SM 3000	x
BUTYL	2680	SM 4000	x
BUTYL	3440	SM 5000	x

COUNTERFLANGE

Diameter	Connection	Finish
95	1"	Galvanized
95	1"	AISI304

