

SCP, SCP4, SCP6

Horizontal, Double Suction Split-Case In-line Pumps

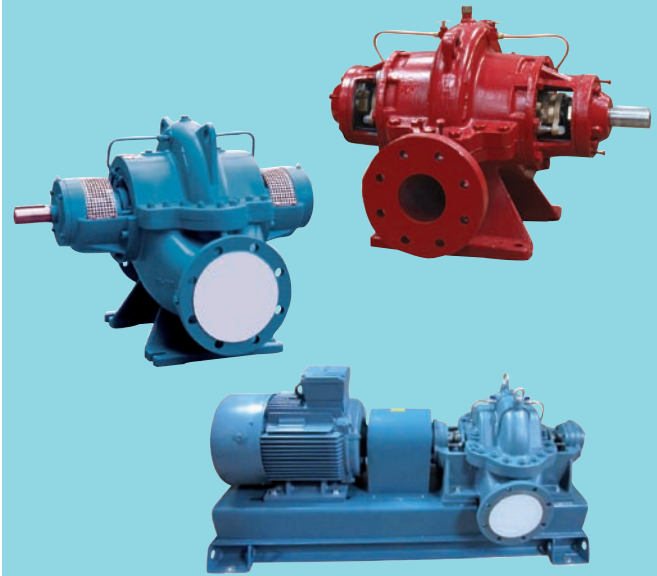

CONSTRUCTION

Single-stage horizontal centrifugal pumps, with suction and discharge flanges on the same axis.

Split case design allows disassembly of pump hydraulic parts without disassembling suction and discharge flanges.

Double suction impeller design increases suction performance and balances axial forces on impeller and shaft.

Rated speed of rotation (50 Hz):

SCP = 2900 1/min.

SCP4 = 1450 1/min.

SCP6 = 960 1/min.

Connections: PN 16 / PN 25 flanges EN 1092-2.

Max. working pressure 16 (25) bar

Shaft sealing

- Standardized mechanical seal in accordance with ISO 3069.
- Stuffing box seal or different mechanical seals (on request).

APPLICATIONS

- For clean liquids, without abrasives, which are non-aggressive for the pump materials (contents of solids up to 0.2 %).
- For water supply.
- For heating, air conditioning, cooling and circulation plants.
- For civil and industrial applications and for agriculture.
- For fire fighting applications.
- For irrigation.

OPERATING CONDITIONS

Liquid temperature from -10°C to + 120°C. (standard mechanical seal)

Ambient temperature up to 40°C.

Total suction lift up to 7 m.

Maximum permissible working pressure up to 16/25 bar.

PUMP-MOTOR UNIT

SCP, SCP4, SCP6 pump connected to a standard electric motor in B3 construction form (IEC 72), IP 54 protection, three-phase 400 V, 50 Hz by means of a baseplate, driven by a flexible coupling and with coupling protection.

SPECIAL FEATURES ON REQUEST

- Special mechanical seal.
- Different construction materials for specific applications.
- Higher or lower liquid or ambient temperatures.
- Other motor protection.
- Explosion proof motor.
- Motor for other voltage.
- Frequency 60 Hz (as per 60 Hz data sheet).

MATERIALS

Pump casing	GG25
Sealing box	(Optional GGG 40 I AISI304 / AISI316 I Bronze)
Bearing housing	
Impeller	
Pump shaft	AISI 420 (Optional AISI 304 I AISI 316)
Wear rings	Bronze (Optional AISI304 I AISI316)
Mechanical seal	Silicon Carbide I Carbon Graphite*
Baseplate	DIN 17100 - St 37, epoxy coated
Coupling guard	EN 294 I DIN 31001, epoxy coated

* Different mechanical seals or soft gland packings are available upon request.

SCP

Horizontal, Double Suction, Split-Case Inline Pumps

2900 1/min

SCP 65-250

SCP 80-200

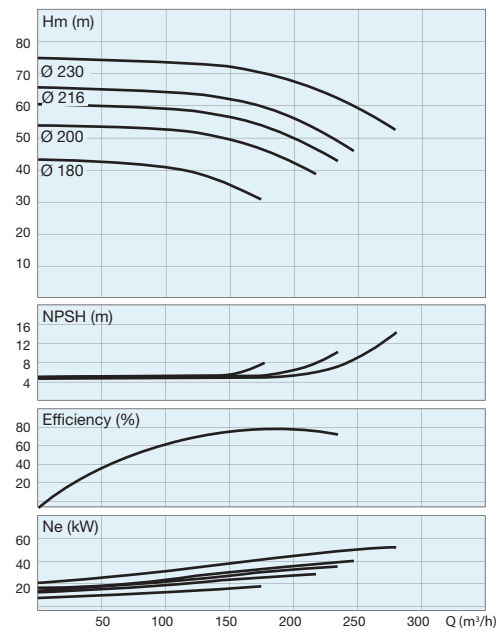
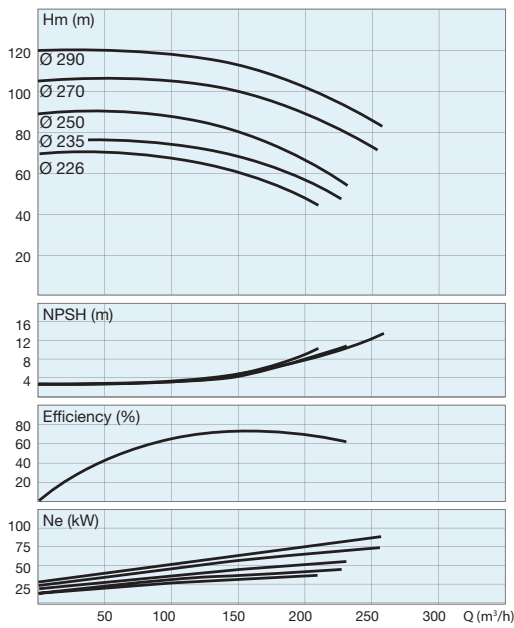

SCP 80-250

SCP 80-315

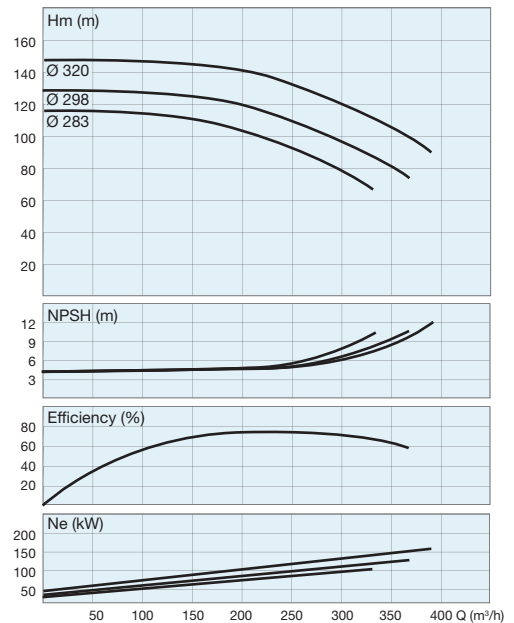
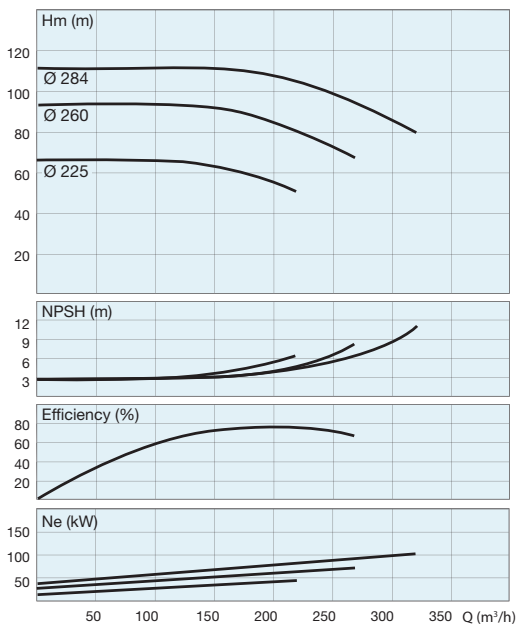

SCP

Horizontal, Double Suction, Split-Case Inline Pumps

2900 1/min

SCP 100-250

SCP 100-315

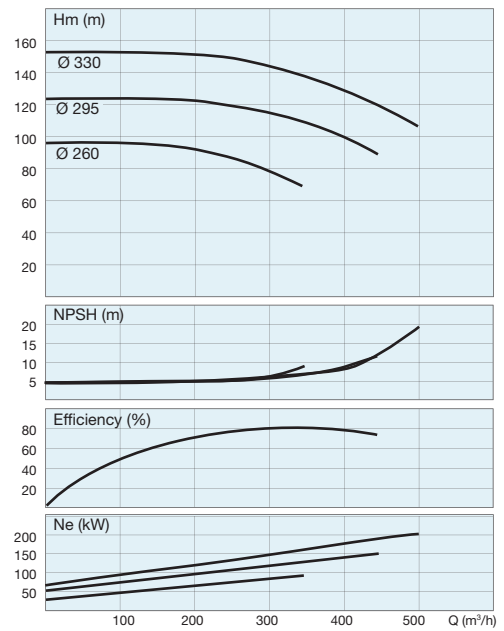
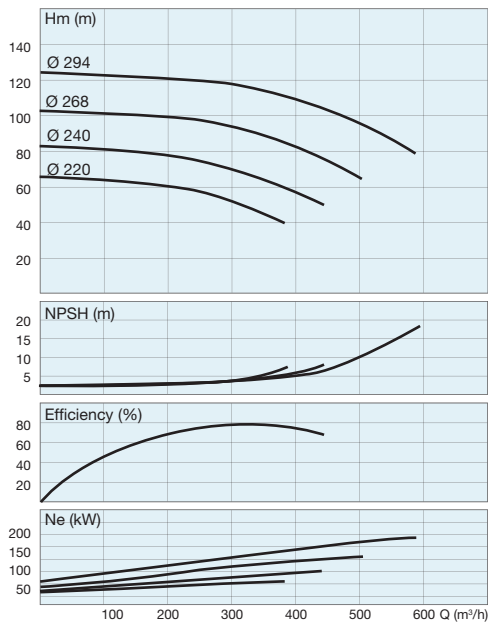

SCP 125-315

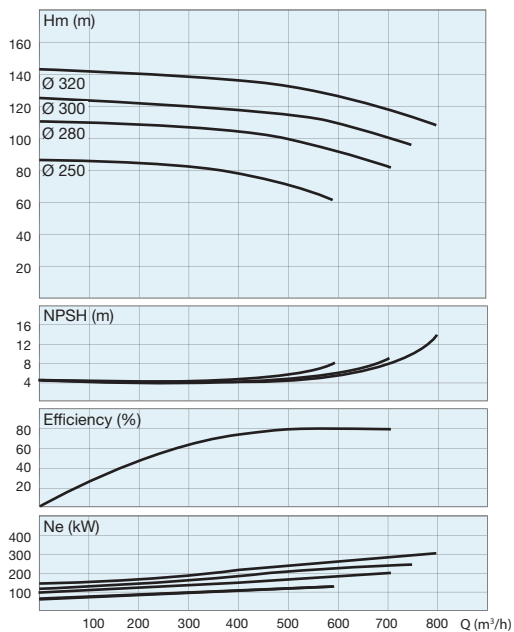

SCP4

Horizontal, Double Suction, Split-Case Inline Pumps

1450 1/min

SCP4 65-250

SCP4 80-200

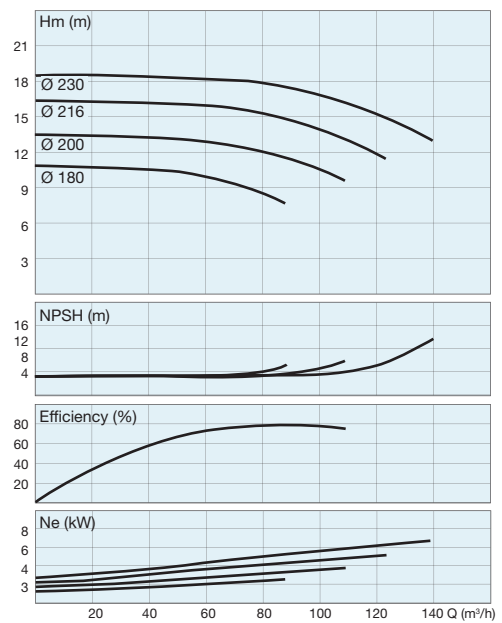
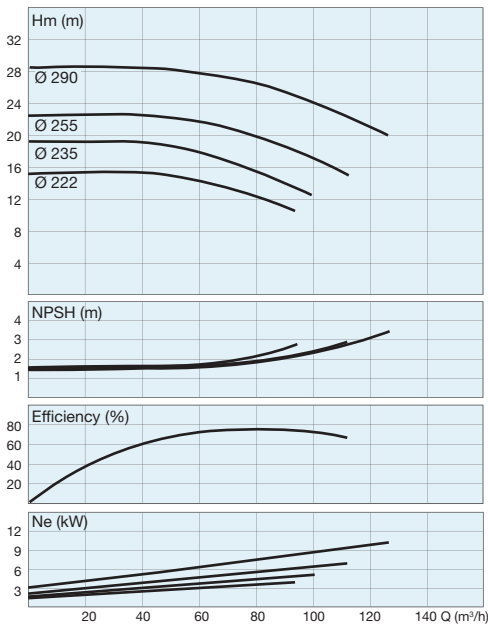

SCP4 80-250

SCP4 80-315

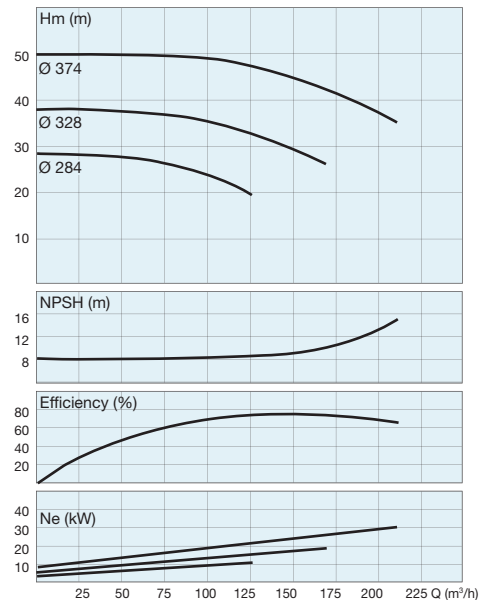
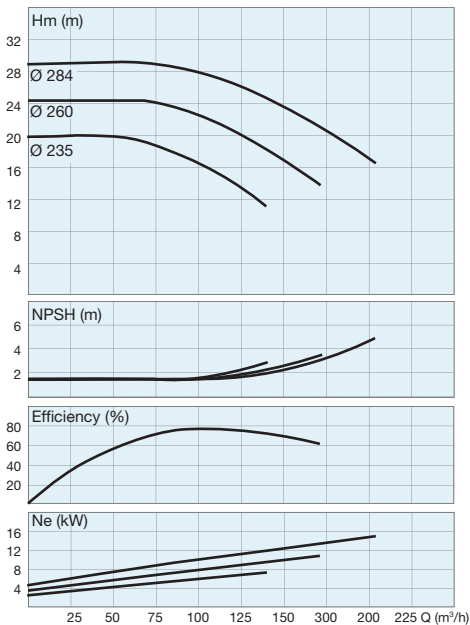

SCP4

Horizontal, Double Suction, Split-Case Inline Pumps

1450 1/min

SCP4 100-250

SCP4 100-315

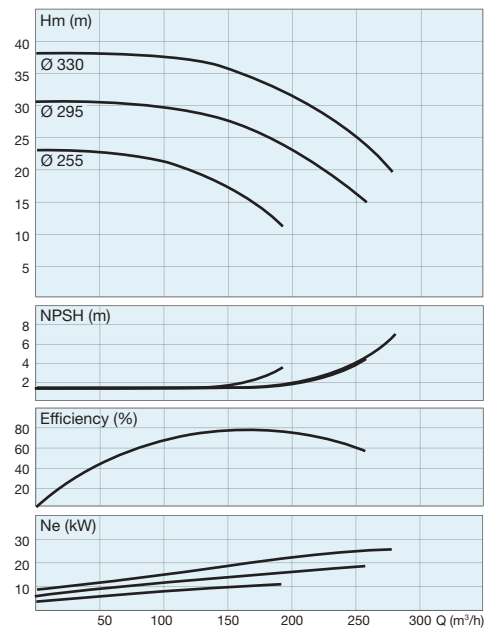
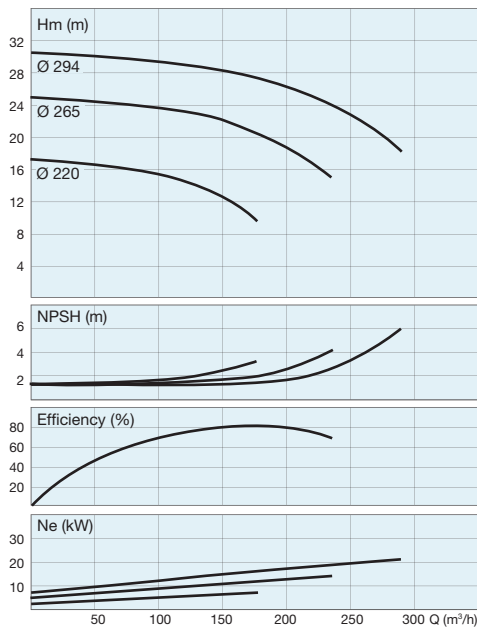

SCP4 100-400

SCP4 125-315

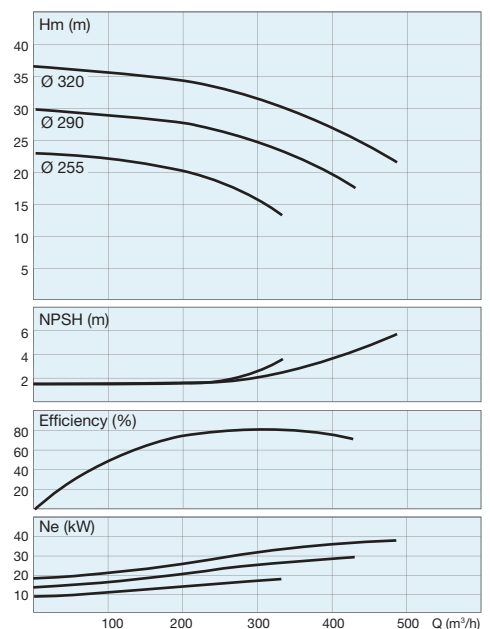
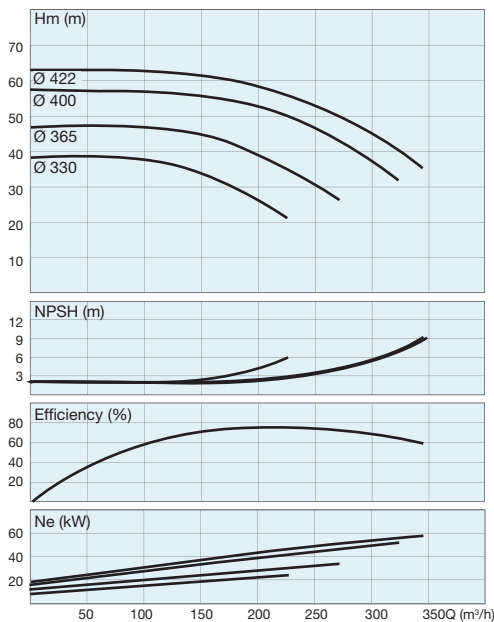

SCP4

Horizontal, Double Suction, Split-Case Inline Pumps

1450 1/min

SCP4 125-350

SCP4 125-450

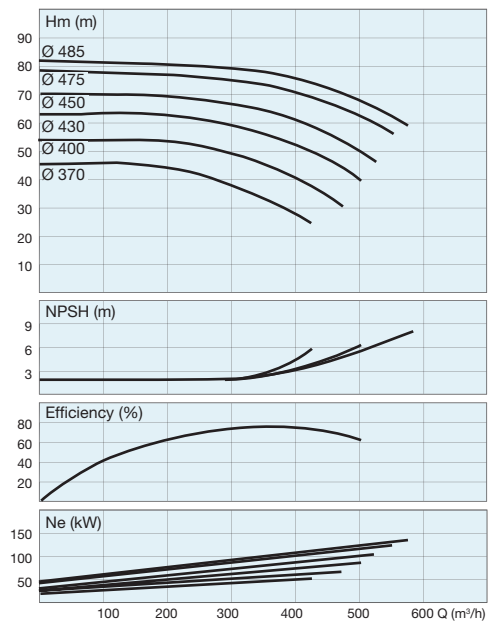
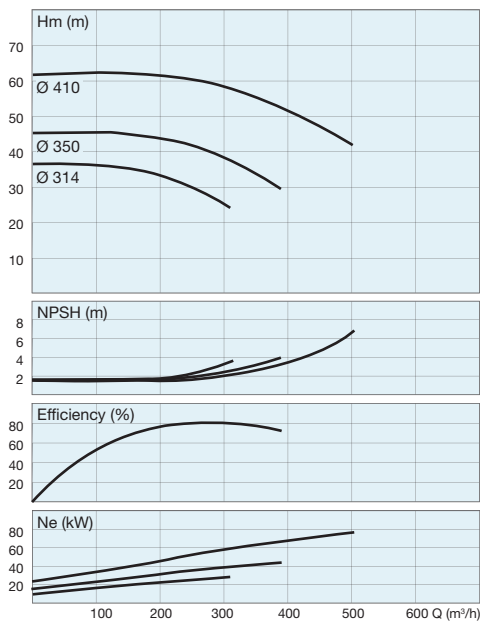

SCP4 150-315

SCP4 150-450

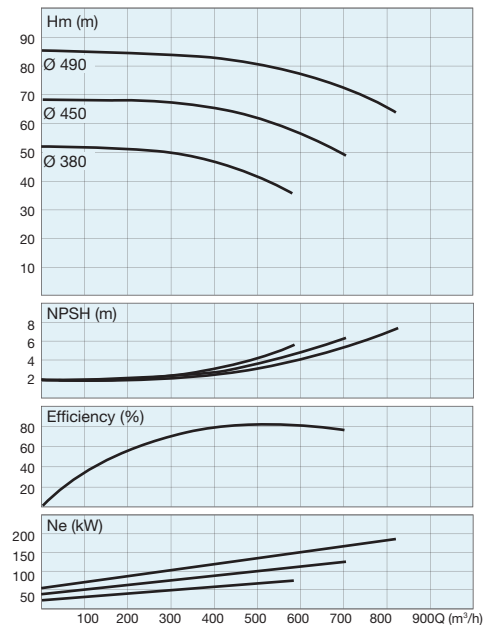
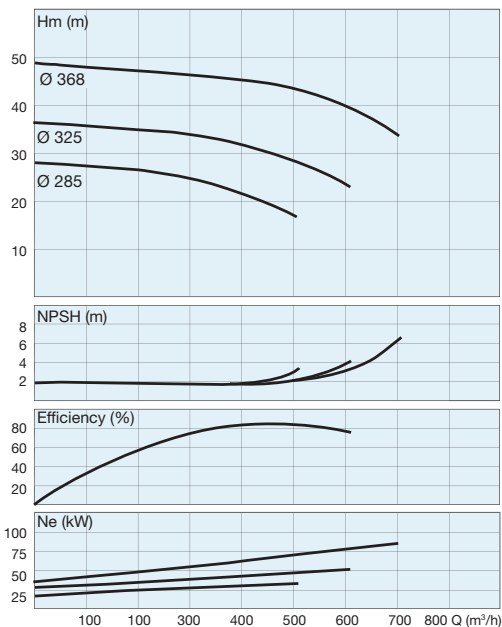

SCP4

Horizontal, Double Suction, Split-Case Inline Pumps

1450 1/min

SCP4 150-600

SCP4 150-630

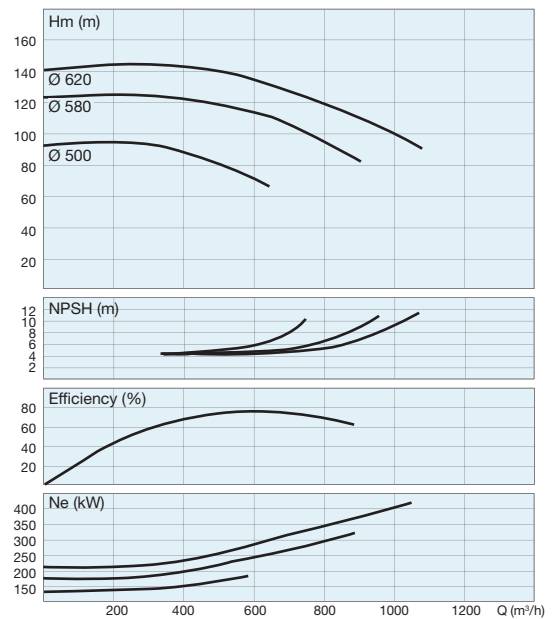
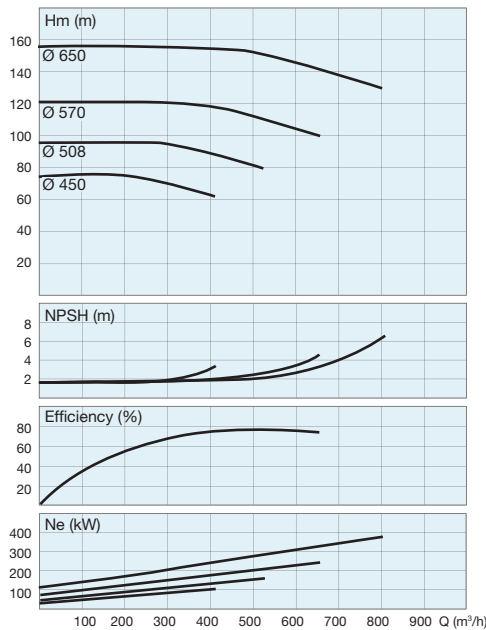

SCP4 200-315

SCP4 200-400

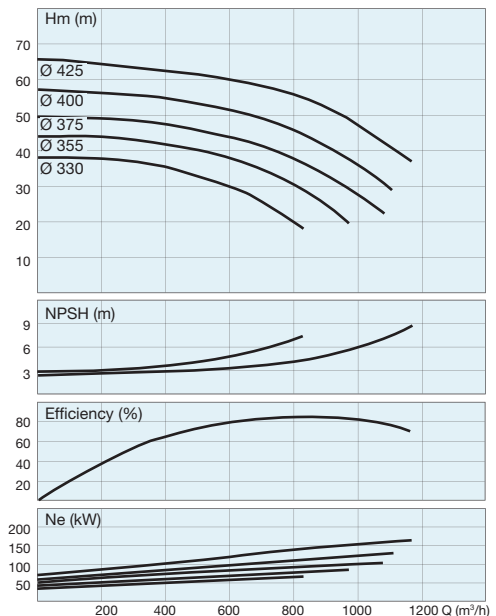
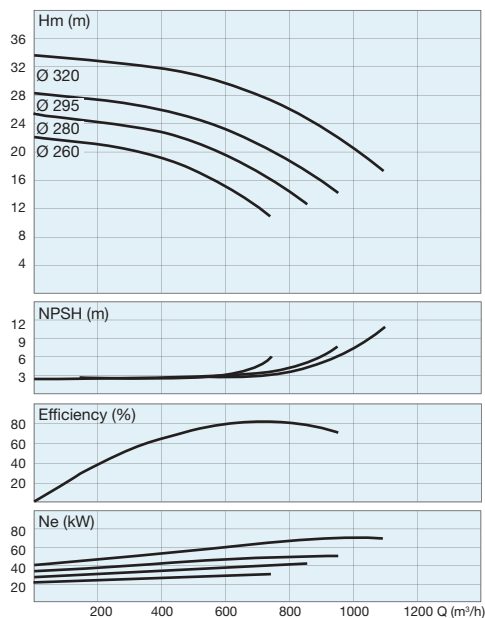

SCP4

Horizontal, Double Suction, Split-Case Inline Pumps

1450 1/min

SCP4 200-500

SCP4 200-720

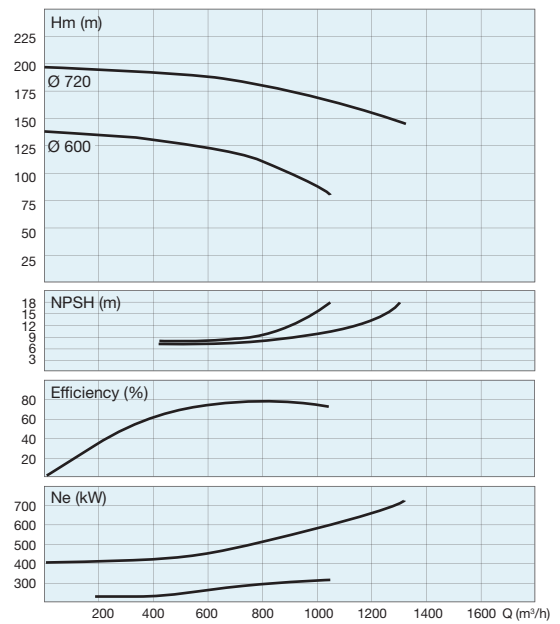
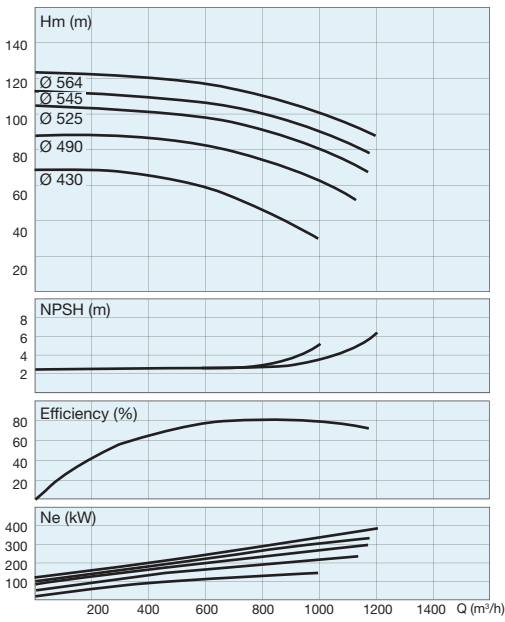

SCP4 250-350

SCP4 250-450

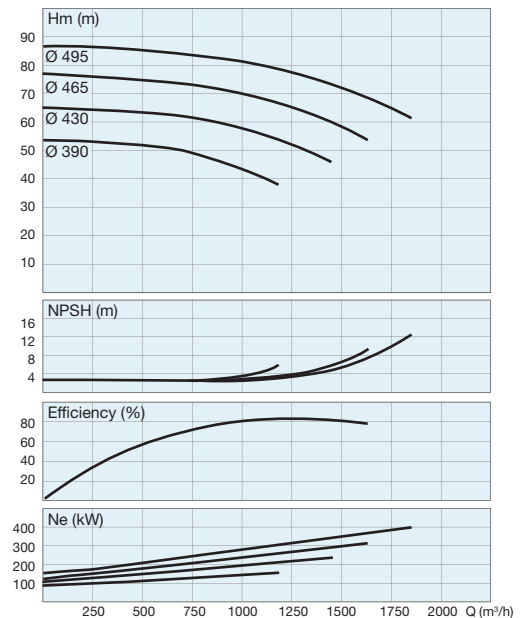
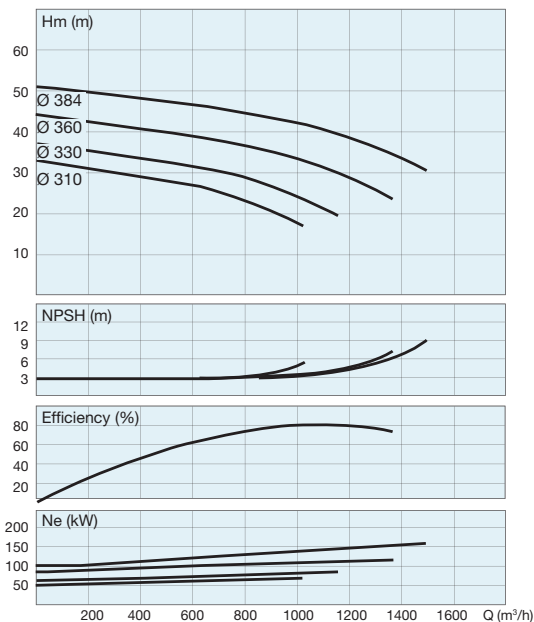

SCP4

Horizontal, Double Suction, Split-Case Inline Pumps

1450 1/min

SCP4 250-600

SCP4 300-315

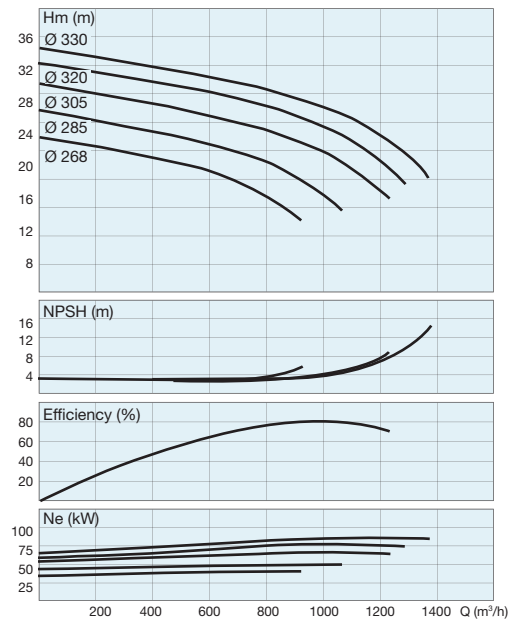
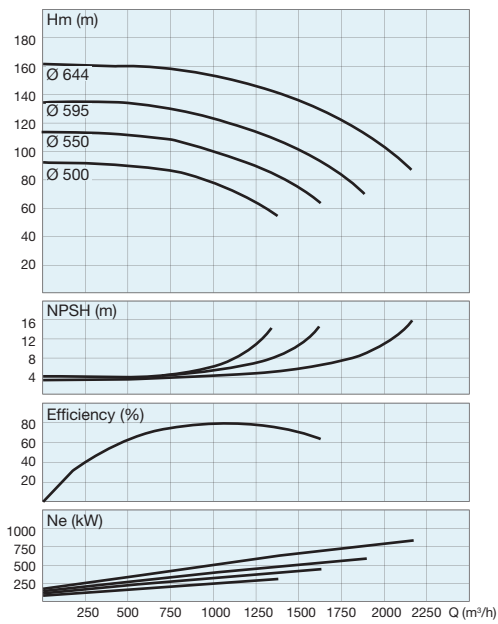

SCP4 300-400

SCP4 300-500

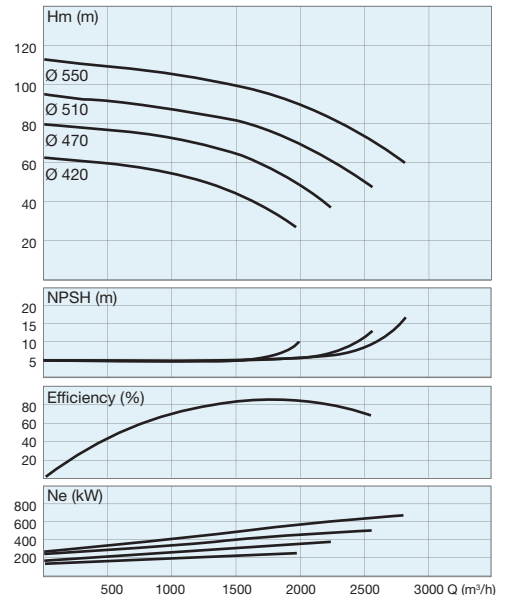
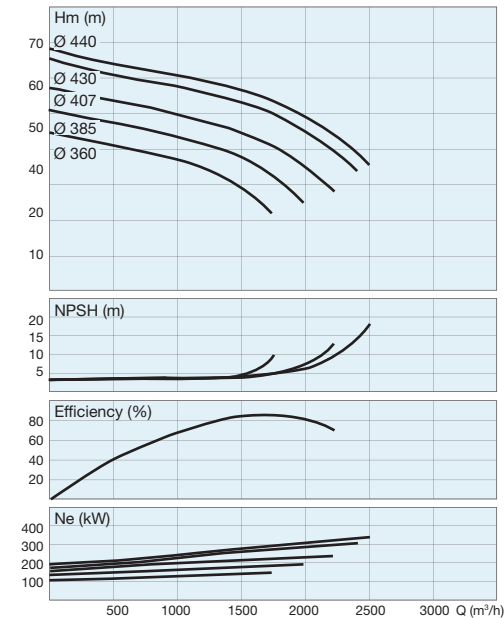

SCP4

Horizontal, Double Suction, Split-Case Inline Pumps

1450 1/min

SCP4 300-700

SCP4 350-350

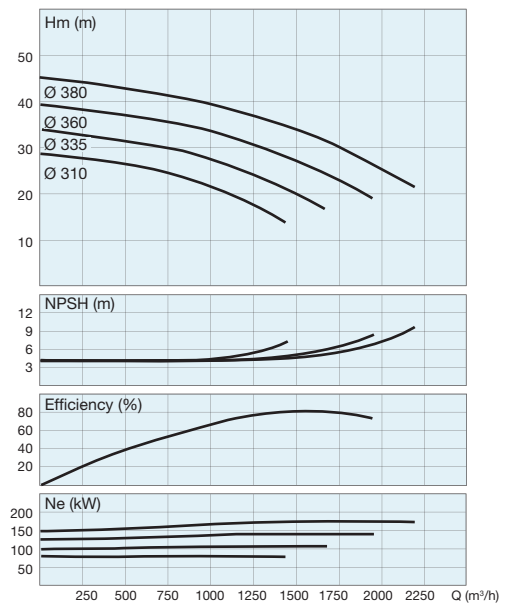
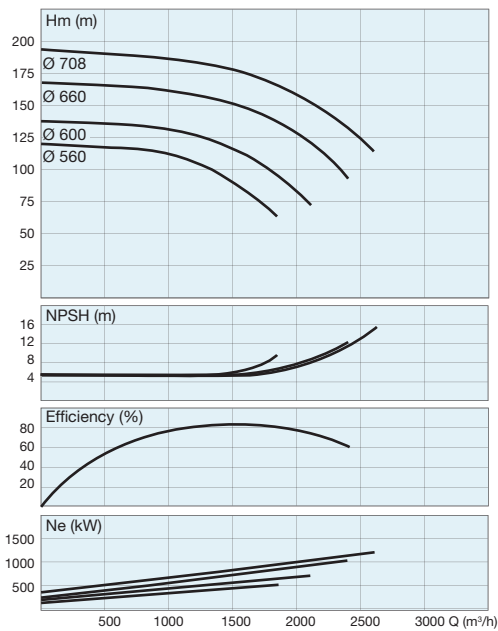

SCP4 350-400

SCP4 350-500

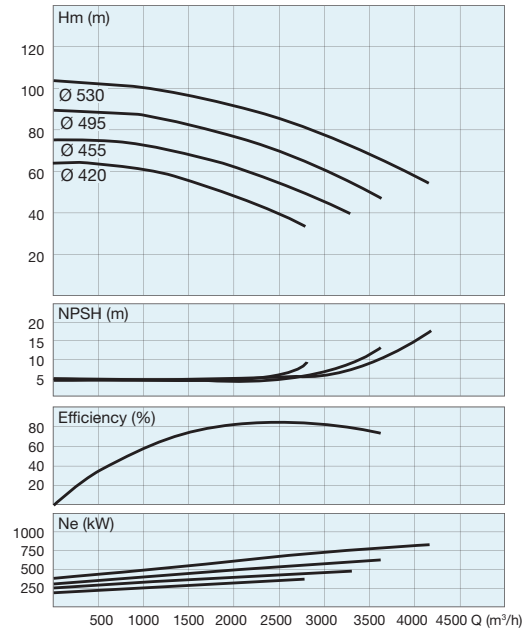
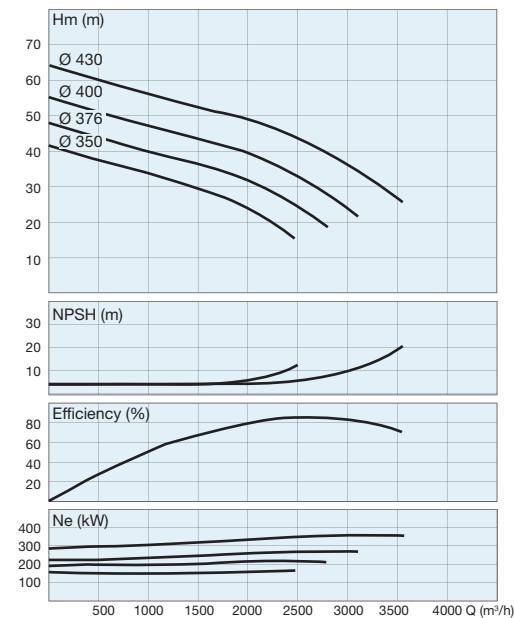

SCP4

Horizontal, Double Suction, Split-Case Inline Pumps

1450 1/min

SCP4 350-700

SCP4 400-500

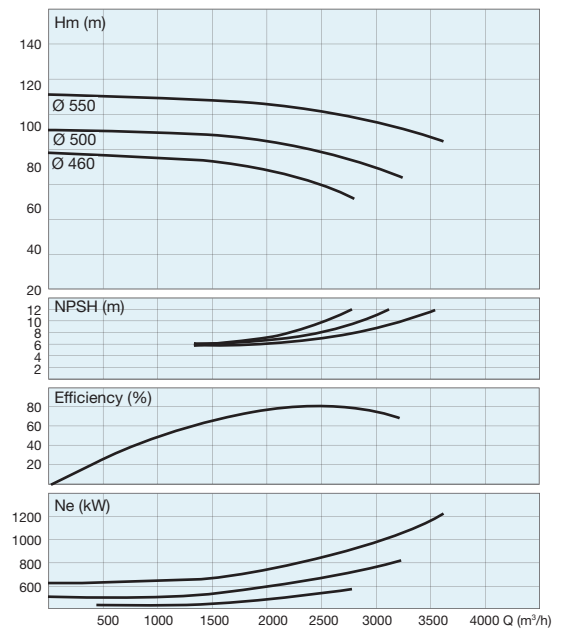
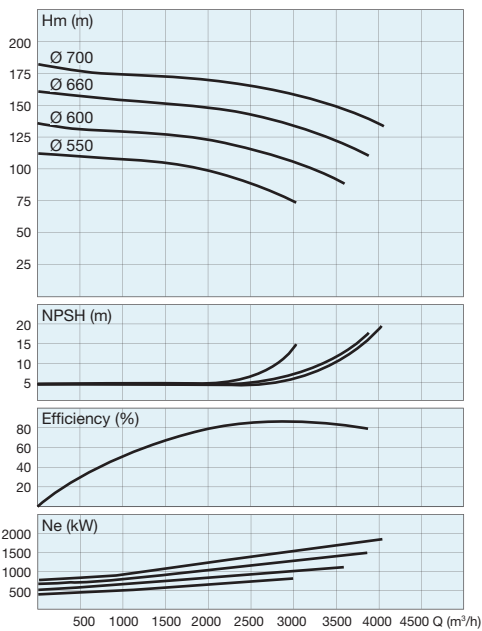

SCP4 400-600

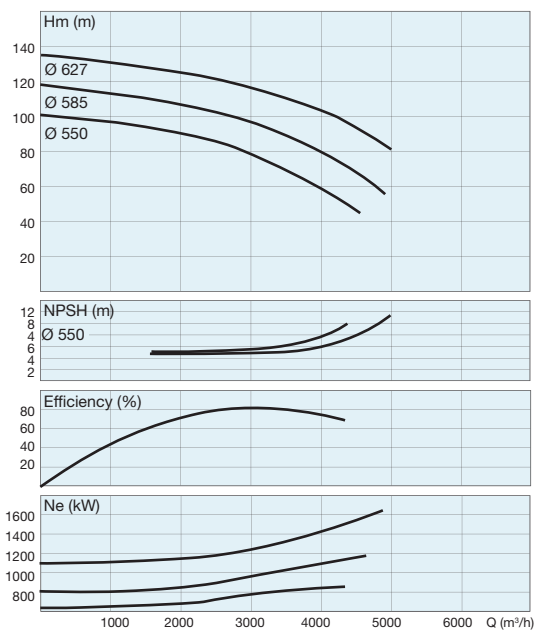

SCP6

Horizontal, Double Suction, Split-Case Inline Pumps

1000 1/min

SCP6 65-250

SCP6 80-200

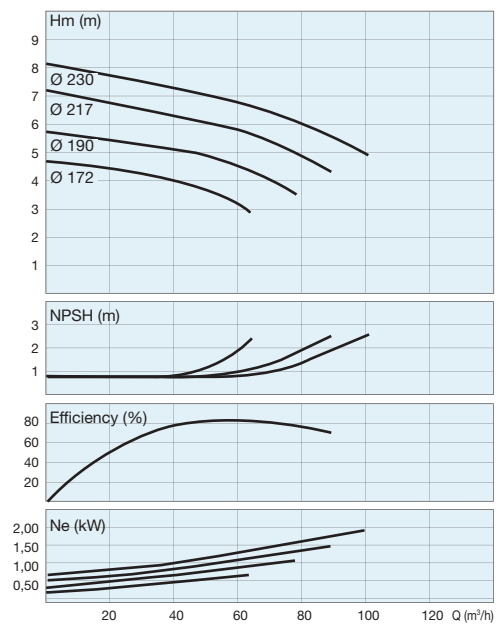
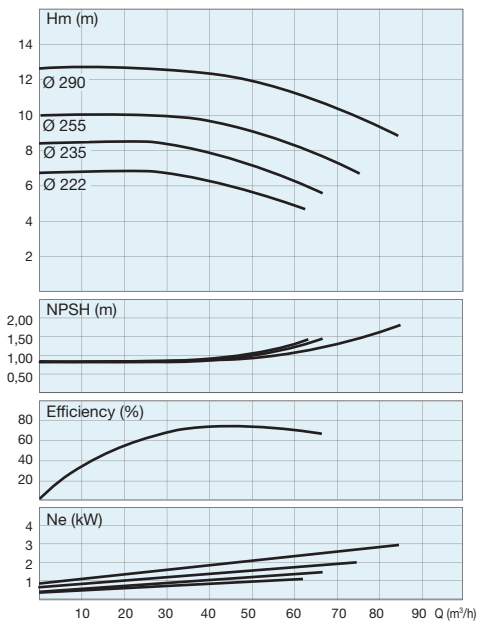

SCP6 80-250

SCP6 80-315

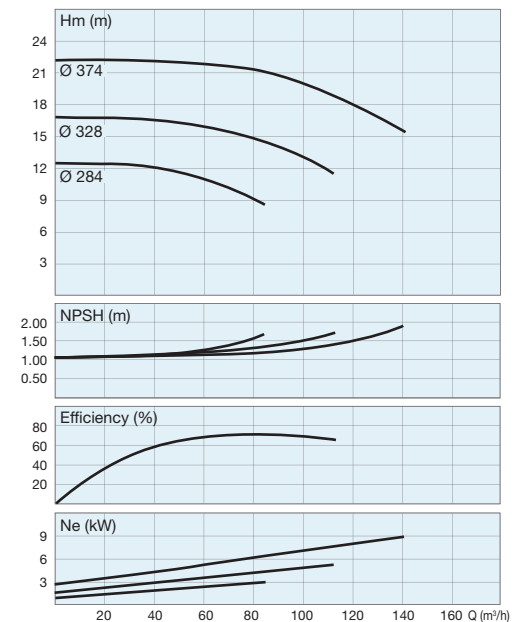
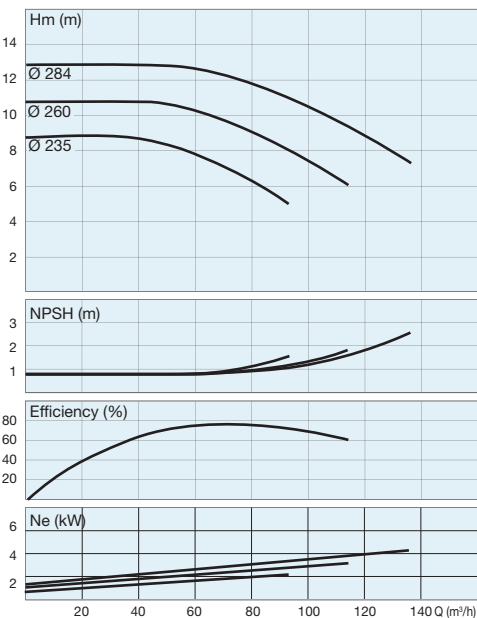

SCP6

Horizontal, Double Suction, Split-Case Inline Pumps

1000 1/min

SCP6 100-250

SCP6 100-315

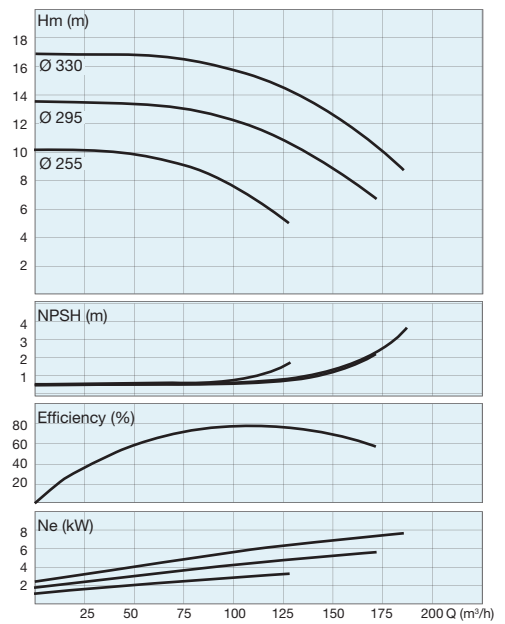
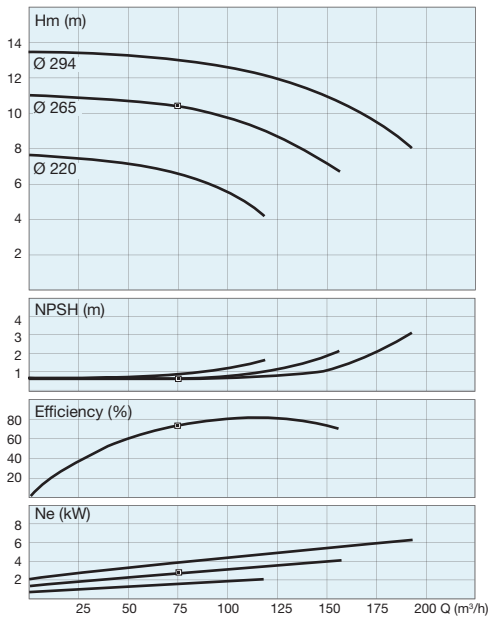

SCP6 100-400

SCP6 125-315

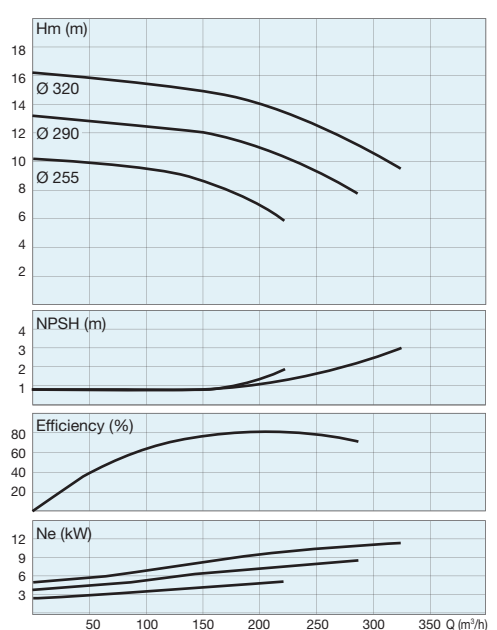
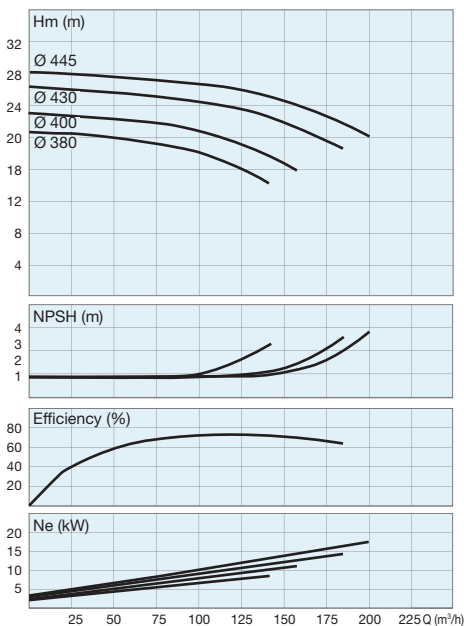

SCP6

Horizontal, Double Suction, Split-Case Inline Pumps

1000 1/min

SCP6 125-350

SCP6 125-450

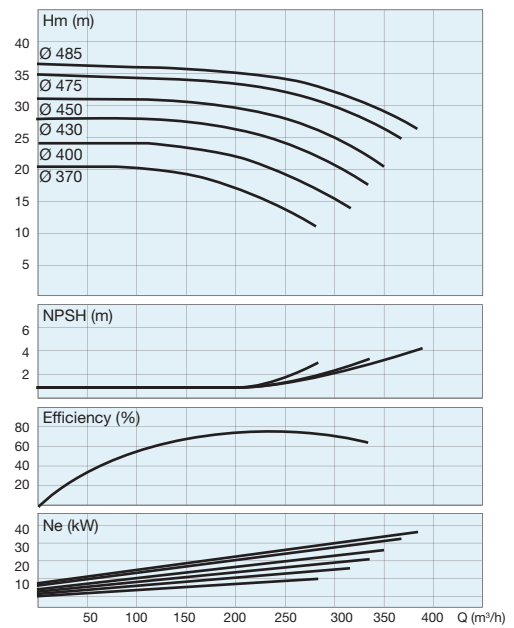
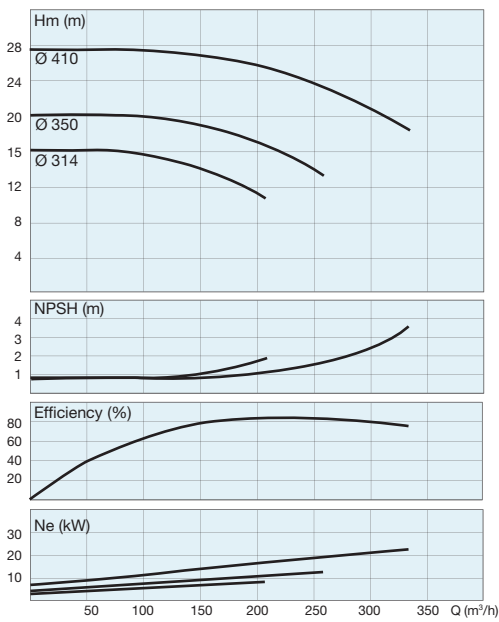

SCP6 150-315

SCP6 150-450

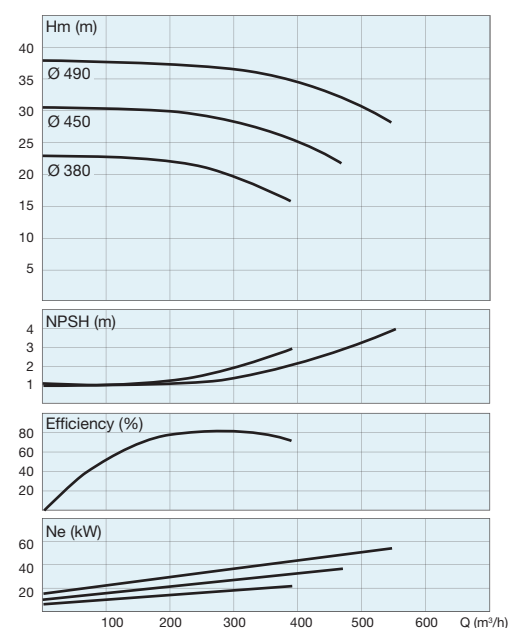
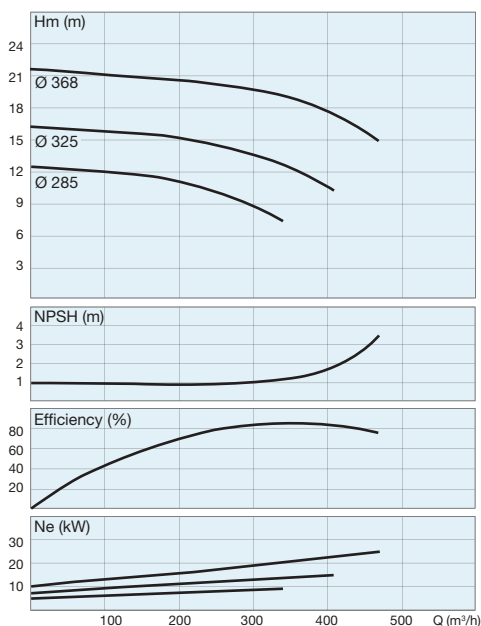

SCP6

Horizontal, Double Suction, Split-Case Inline Pumps

1000 1/min

SCP6 150-550

SCP6 150-600

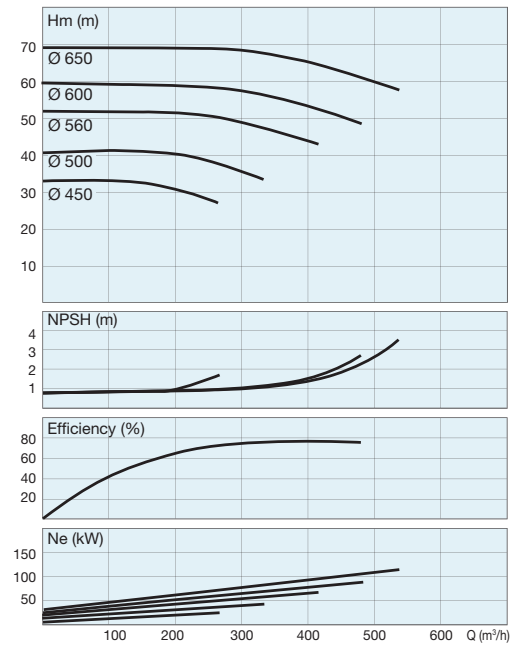
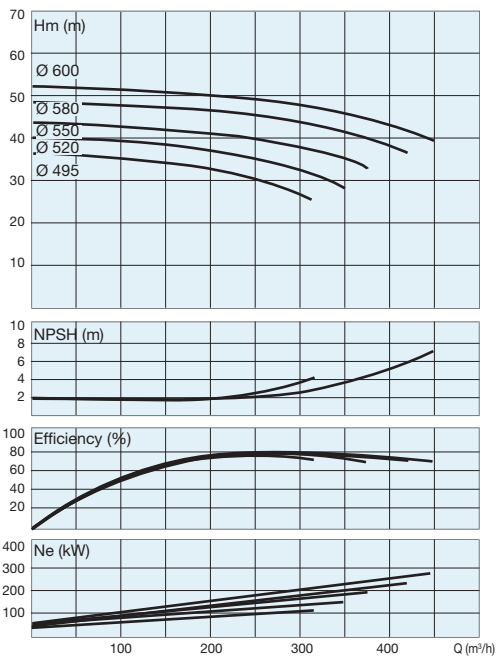

SCP6 200-315

SCP6 200-400

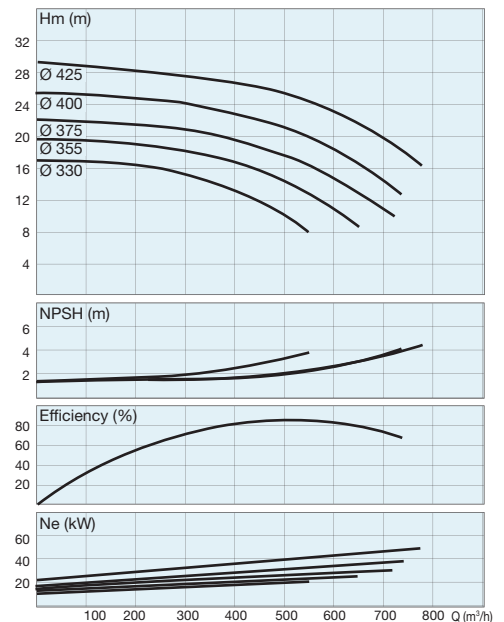
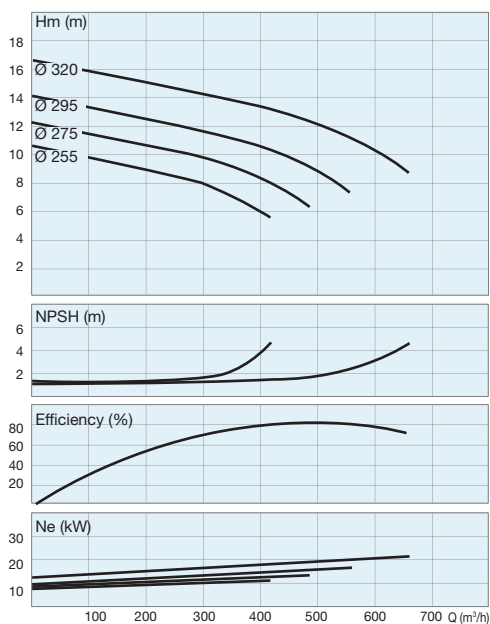

SCP6

Horizontal, Double Suction, Split-Case Inline Pumps

1000 1/min

SCP6 200-500

SCP6 200-600

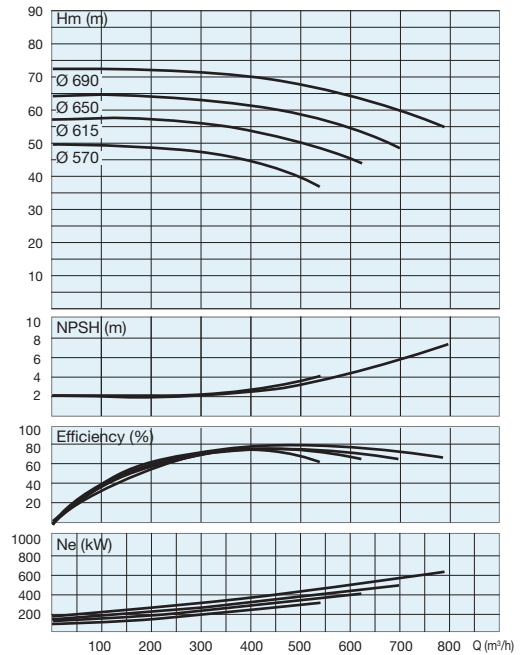
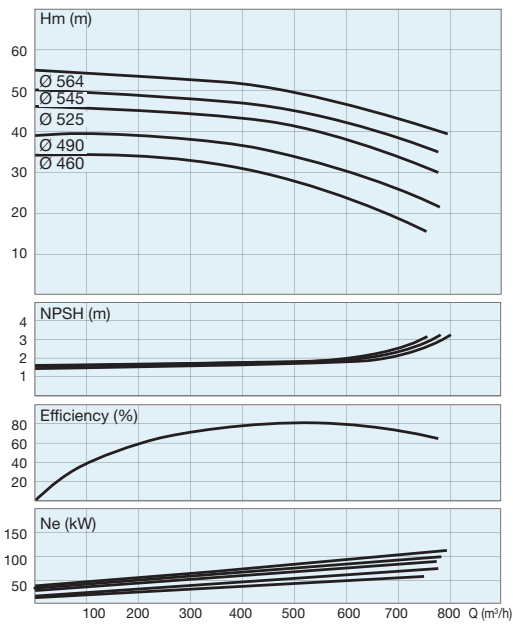

SCP6 250-350

SCP6 250-450

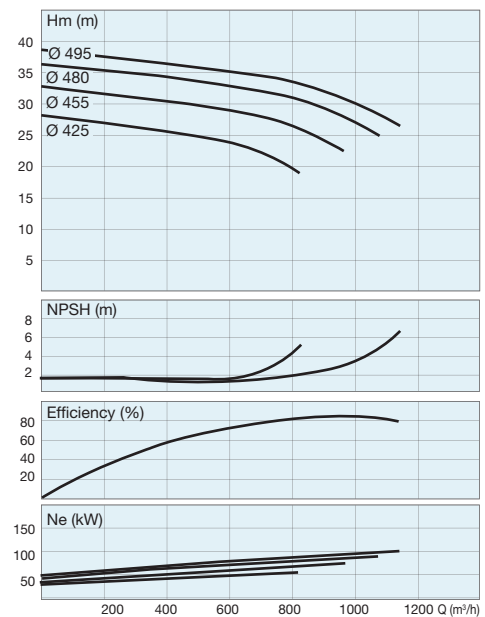
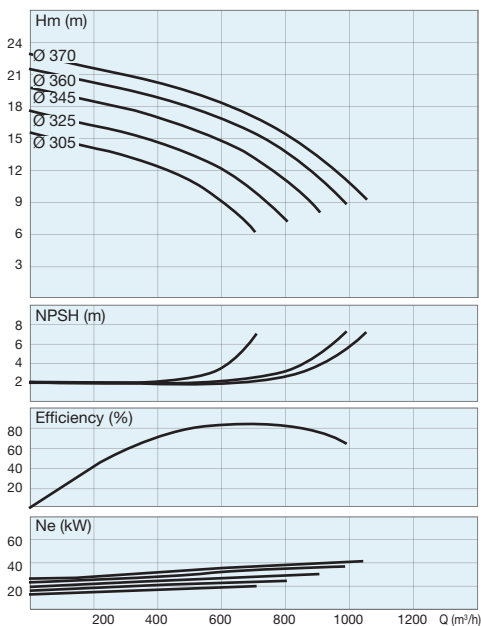

SCP6

Horizontal, Double Suction, Split-Case Inline Pumps

1000 1/min

SCP6 250-600

SCP6 300-315

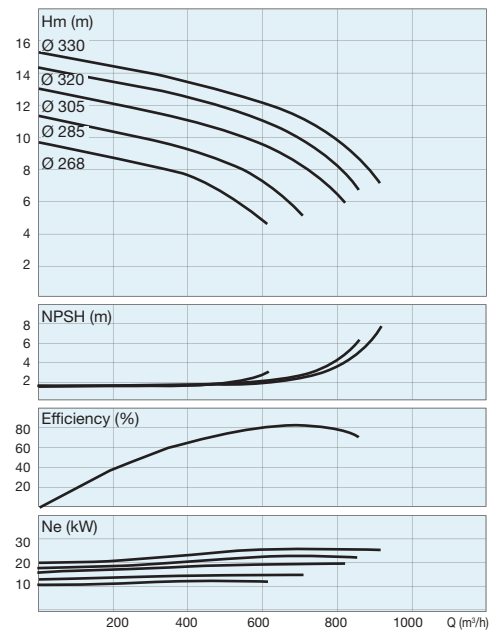
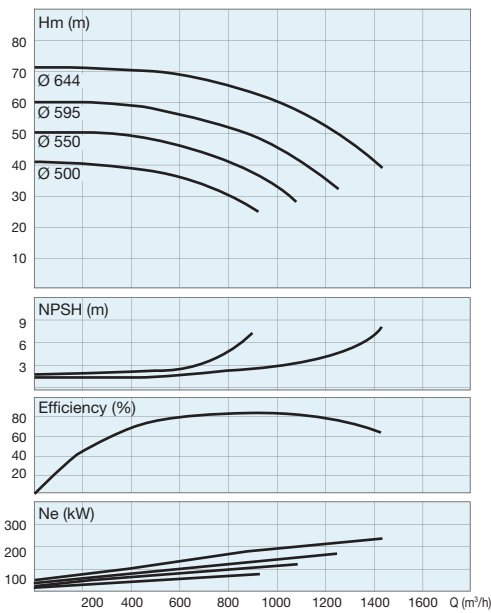

SCP6 300-400

SCP6 300-500

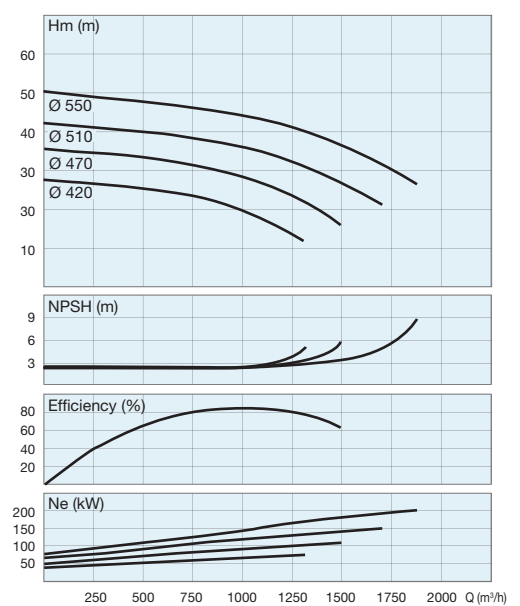
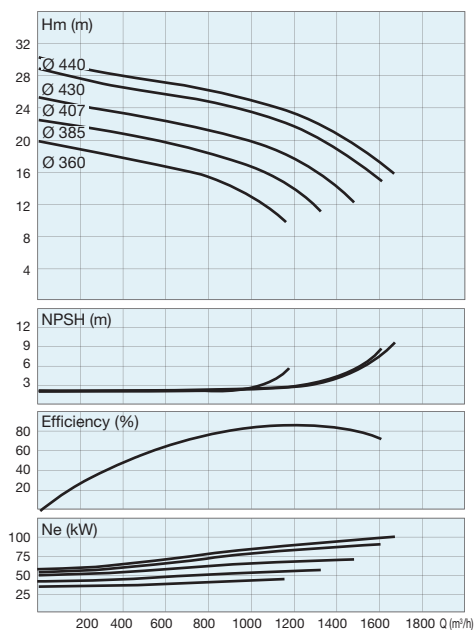

SCP6

Horizontal, Double Suction, Split-Case Inline Pumps

1000 1/min

SCP6 300-700

SCP6 350-350

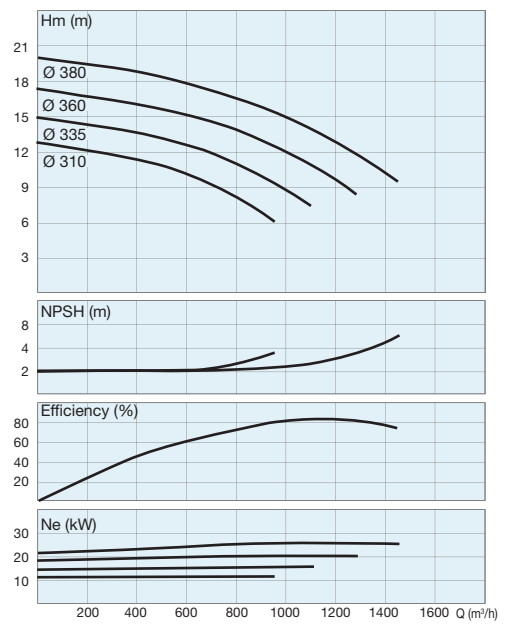
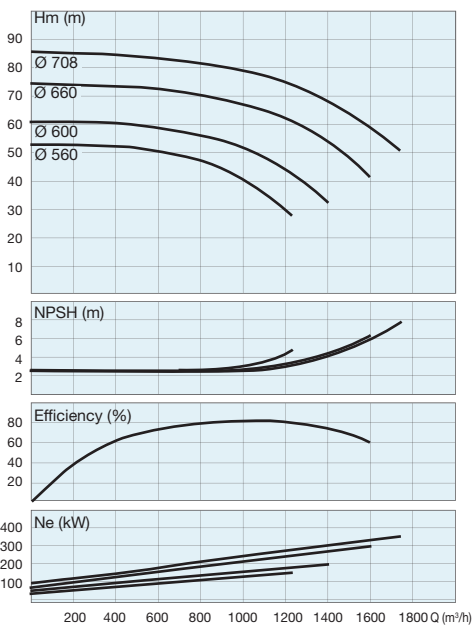

SCP6 350-400

SCP6 350-500

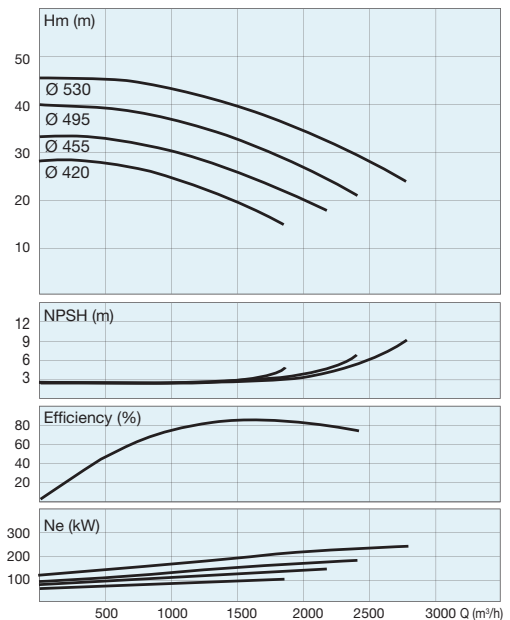
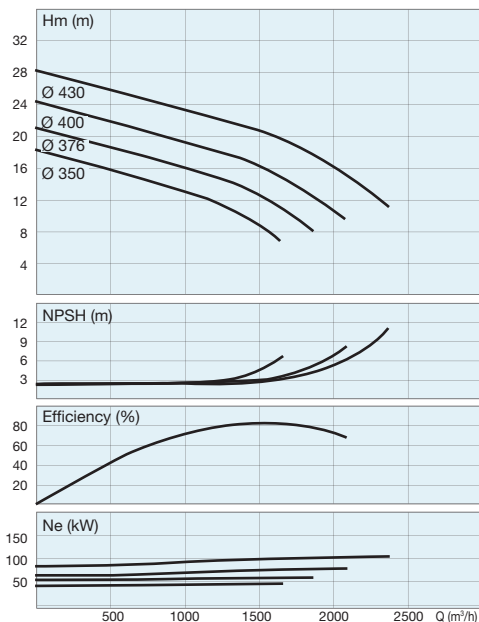

SCP6

Horizontal, Double Suction, Split-Case Inline Pumps

1000 1/min

SCP6 350-700

SCP6 400-500

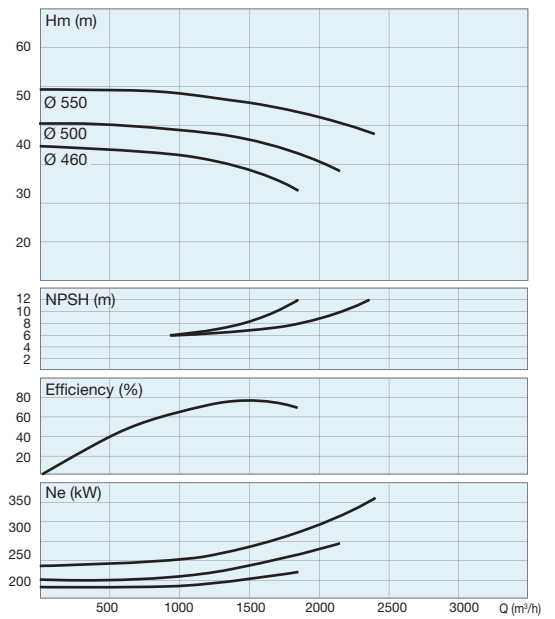
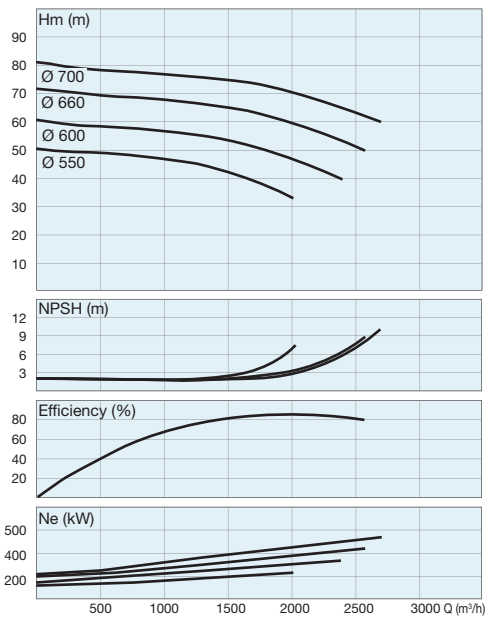

SCP6 400-600

SCP6 400-630

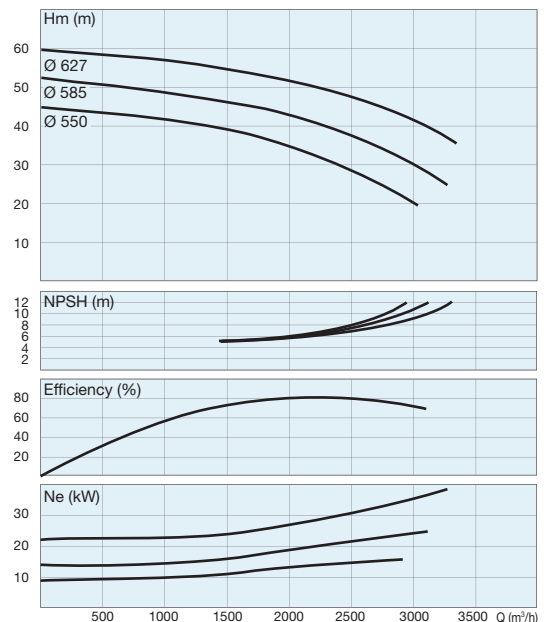
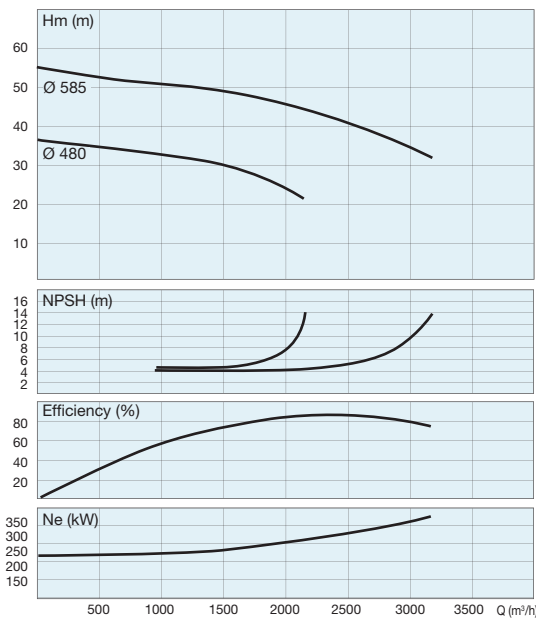

SCP6

Horizontal, Double Suction, Split-Case Inline Pumps

1000 1/min

SCP6 500-540

SCP6 500-620

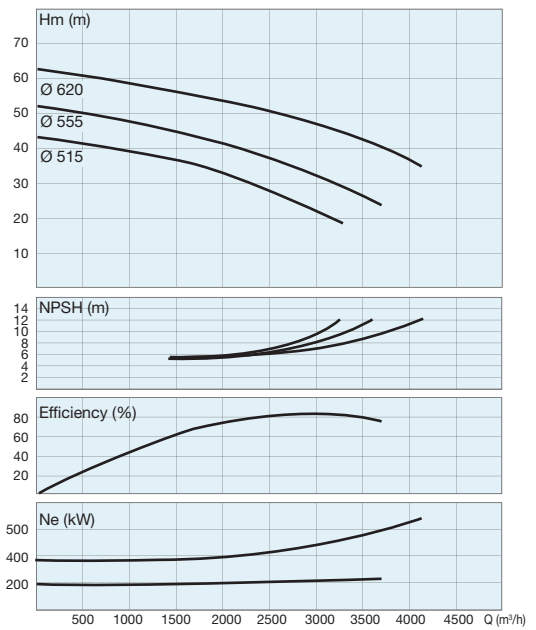
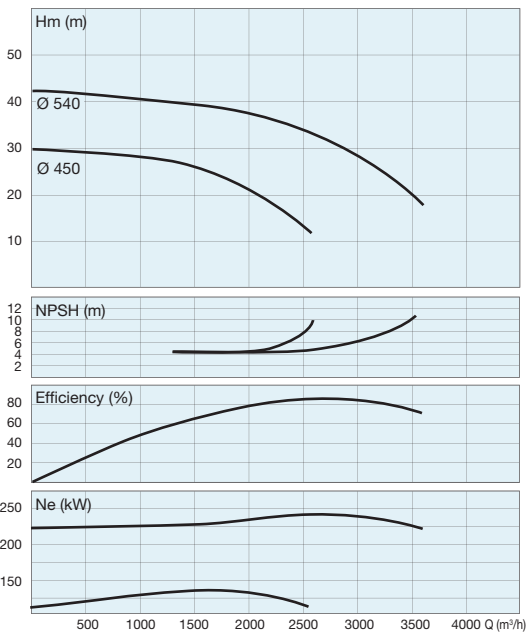

SCP6 500-650

SCP6 500-800

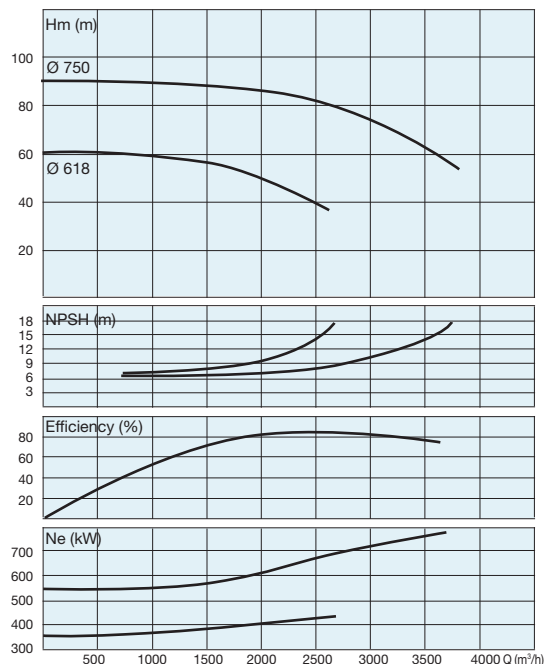
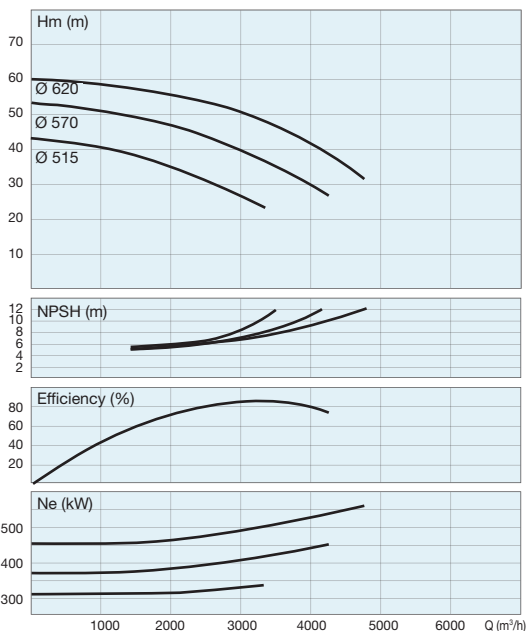

SCP6

Horizontal, Double Suction, Split-Case Inline Pumps

1000 1/min

SCP6 500-900

SCP6 600-800

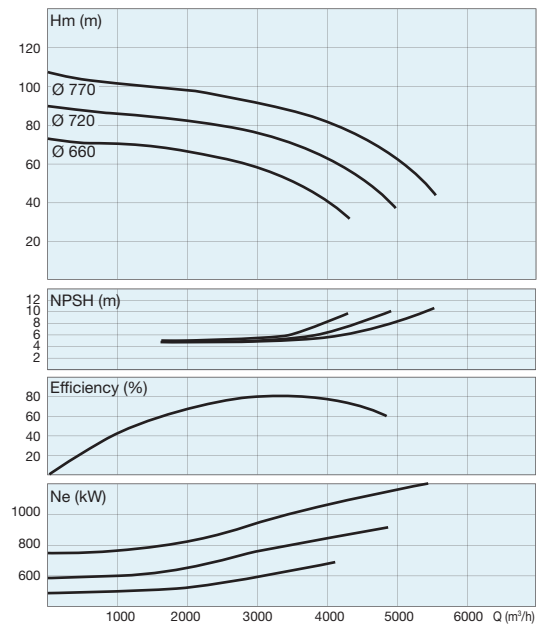
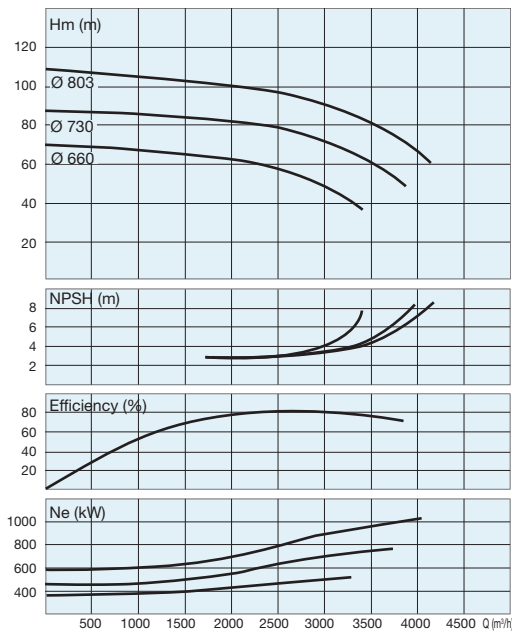

SCP6 700-700

SCP6 700-710

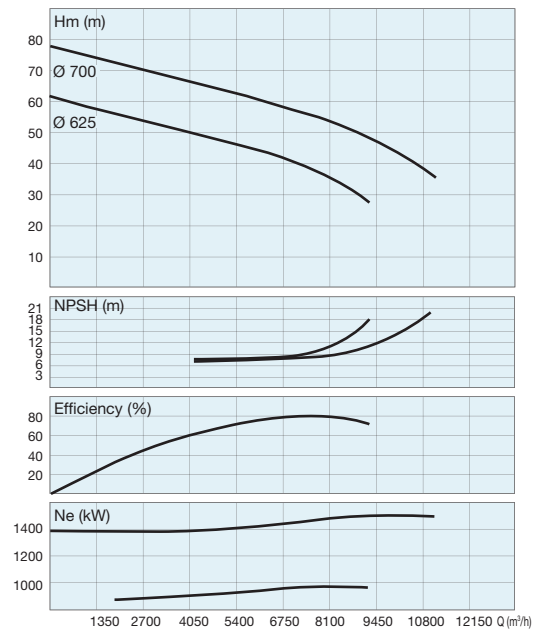
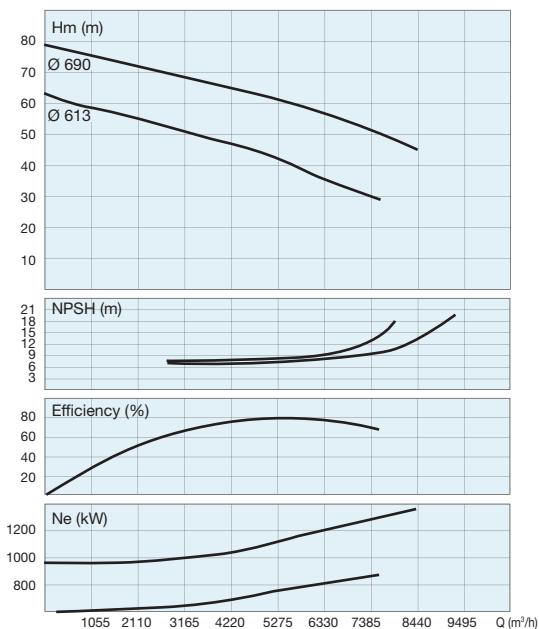

SCP

Horizontal, Double Suction, Split-Case Inline Pumps

Dimensions

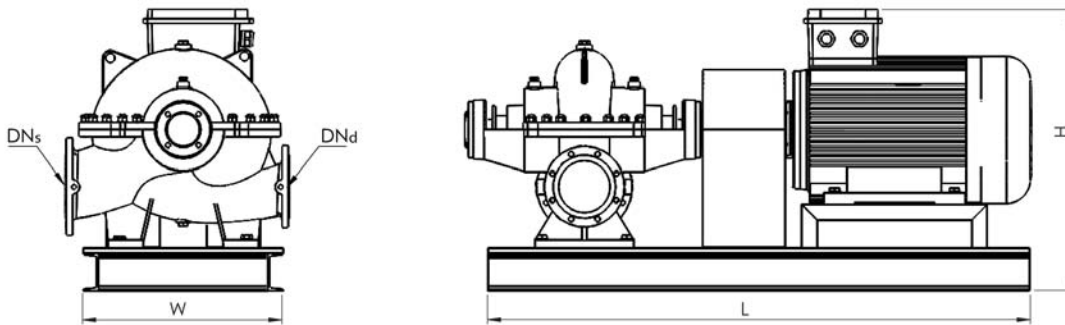

Model	kW	rpm	DN _s	DN _d	kg	w	l	h
SCP 65-250	30	3000	100	65	405	600	1480	1400
SCP 65-250	37	3000	100	65	420	600	1525	1400
SCP 65-250	45	3000	100	65	474	600	1555	1400
SCP 65-250	55	3000	100	65	568	600	1620	1400
SCP 65-250	75	3000	100	65	709	600	1695	1400
SCP 80-200	22	3000	125	80	345	600	1450	1400
SCP 80-200	30	3000	125	80	405	600	1480	1400
SCP 80-200	37	3000	125	80	420	600	1525	1400
SCP 80-200	45	3000	125	80	474	600	1555	1400
SCP 80-200	55	3000	125	80	568	600	1620	1400
SCP 80-250	55	3000	125	80	578	600	1620	1400
SCP 80-250	75	3000	125	80	719	600	1695	1400
SCP 80-250	90	3000	125	80	795	600	1745	1400
SCP 80-250	110	3000	125	80	1155	635	1925	1400
SCP 80-315	75	3000	125	80	741	660	1695	1400
SCP 80-315	90	3000	125	80	817	660	1745	1400
SCP 80-315	110	3000	125	80	1177	660	1925	1400
SCP 80-315	132	3000	125	80	1277	660	2035	1400
SCP 100-250	75	3000	150	100	764	670	1785	1400
SCP 100-250	90	3000	150	100	840	670	1835	1400
SCP 100-250	110	3000	150	100	1200	670	2015	1400
SCP 100-250	132	3000	150	100	1300	670	2125	1400
SCP 100-250	160	3000	150	100	1380	670	2125	1400
SCP 100-250	185	3000	150	100	1380	730	2330	1400
SCP 100-315	90	3000	150	100	850	670	1835	1400
SCP 100-315	110	3000	150	100	1210	670	2015	1400
SCP 100-315	132	3000	150	100	1310	670	2125	1400
SCP 100-315	160	3000	150	100	1390	670	2125	1400
SCP 100-315	185	3000	150	100	1390	730	2330	1400
SCP 100-315	200	3000	150	100	1420	730	2330	1400
SCP 125-315	110	3000	200	125	1310	690	2190	1400
SCP 125-315	132	3000	200	125	1410	690	2300	1400
SCP 125-315	160	3000	200	125	1490	690	2300	1400
SCP 125-315	185	3000	200	125	1490	730	2505	1400
SCP 125-315	200	3000	200	125	1520	730	2505	1400
SCP 125-315	250	3000	200	125	1520	806	2895	1400

SCP4

Horizontal, Double Suction, Split-Case Inline Pumps

Dimensions

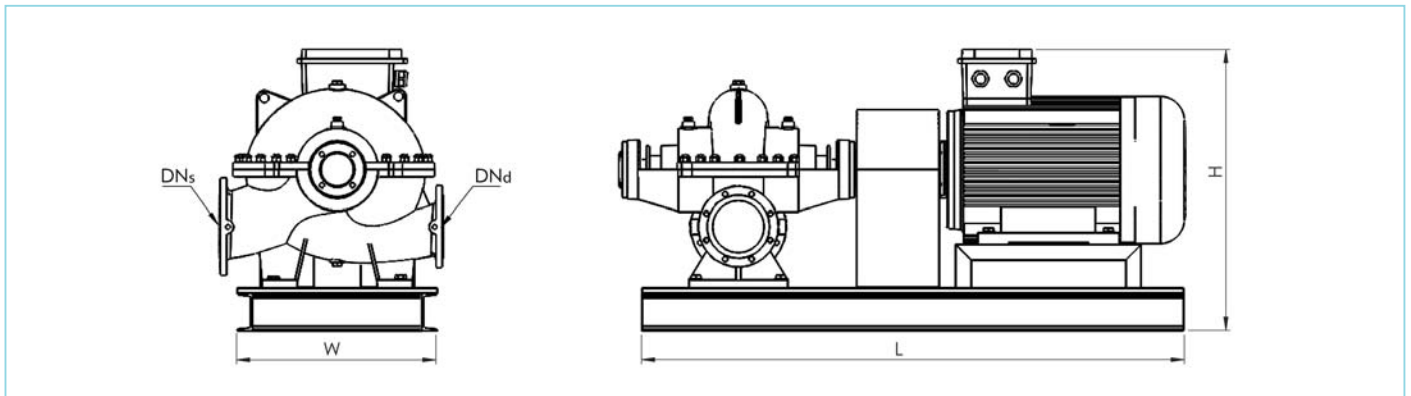

Model	kW	rpm	DN _s	DN _d	kg	w	l	h
SCP4 65-250	3	1500	100	65	284	600	1325	1400
SCP4 65-250	4	1500	100	65	284	600	1325	1400
SCP4 65-250	5,5	1500	100	65	284	600	1325	1400
SCP4 65-250	7,5	1500	100	65	284	600	1325	1400
SCP4 65-250	11	1500	100	65	312	600	1325	1400
SCP4 80-200	5,5	1500	125	80	284	600	1325	1400
SCP4 80-200	7,5	1500	125	80	284	600	1325	1400
SCP4 80-200	11	1500	125	80	312	600	1325	1400
SCP4 80-200	15	1500	125	80	309	600	1380	1400
SCP4 80-200	18,5	1500	125	80	347	600	1410	1400
SCP4 80-200	22	1500	125	80	355	600	1450	1400
SCP4 80-250	11	1500	125	80	322	600	1325	1400
SCP4 80-250	15	1500	125	80	319	600	1380	1400
SCP4 80-250	18,5	1500	125	80	357	600	1410	1400
SCP4 80-250	22	1500	125	80	365	600	1450	1400
SCP4 80-250	30	1500	125	80	445	600	1480	1400
SCP4 80-315	11	1500	125	80	344	660	1325	1400
SCP4 80-315	15	1500	125	80	341	660	1380	1400
SCP4 80-315	18,5	1500	125	80	379	660	1410	1400
SCP4 80-315	22	1500	125	80	387	660	1450	1400
SCP4 80-315	30	1500	125	80	467	660	1480	1400
SCP4 100-250	7,5	1500	150	100	339	670	1415	1400
SCP4 100-250	11	1500	150	100	367	670	1415	1400
SCP4 100-250	15	1500	150	100	364	670	1470	1400
SCP4 100-250	18,5	1500	150	100	402	670	1500	1400
SCP4 100-250	22	1500	150	100	410	670	1540	1400
SCP4 100-315	11	1500	150	100	377	670	1415	1400
SCP4 100-315	15	1500	150	100	374	670	1470	1400
SCP4 100-315	18,5	1500	150	100	412	670	1500	1400
SCP4 100-315	22	1500	150	100	420	670	1540	1400
SCP4 100-315	30	1500	150	100	500	670	1570	1400
SCP4 100-400	22	1500	150	100	480	790	1540	1400
SCP4 100-400	30	1500	150	100	560	790	1570	1400
SCP4 100-400	37	1500	150	100	574	790	1615	1400

SCP4

Horizontal, Double Suction, Split-Case Inline Pumps

Dimensions

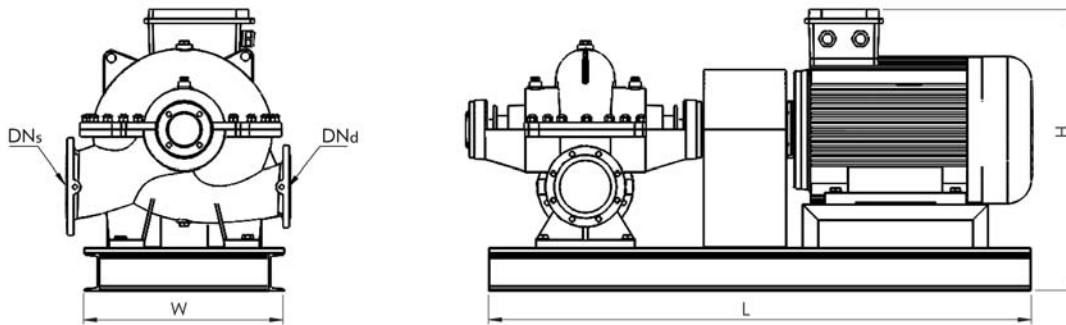

Model	kW	rpm	DNs	DNd	kg	w	l	h
SCP4 100-400	45	1500	150	100	610	790	1645	1400
SCP4 100-400	55	1500	150	100	717	790	1710	1400
SCP4 100-400	75	1500	150	100	852	790	1785	1400
SCP4 125-315	18,5	1500	200	125	512	790	1675	1400
SCP4 125-315	22	1500	200	125	520	790	1715	1400
SCP4 125-315	30	1500	200	125	600	790	1745	1400
SCP4 125-315	37	1500	200	125	614	790	1790	1400
SCP4 125-350	15	1500	200	125	524	920	1645	1400
SCP4 125-350	18,5	1500	200	125	562	920	1675	1400
SCP4 125-350	22	1500	200	125	570	920	1715	1400
SCP4 125-350	30	1500	200	125	650	920	1745	1400
SCP4 125-350	37	1500	200	125	664	920	1790	1400
SCP4 125-350	45	1500	200	125	700	920	1820	1400
SCP4 125-350	55	1500	200	125	807	920	1885	1400
SCP4 125-350	75	1500	200	125	942	920	1960	1400
SCP4 125-350	90	1500	200	125	1047	920	2010	1400
SCP4 125-450	45	1500	200	125	730	950	1820	1400
SCP4 125-450	55	1500	200	125	837	950	1885	1400
SCP4 125-450	75	1500	200	125	972	950	1960	1400
SCP4 125-450	90	1500	200	125	1077	950	2010	1400
SCP4 125-450	110	1500	200	125	1410	950	2190	1400
SCP4 125-450	132	1500	200	125	1510	950	2300	1400
SCP4 125-450	160	1500	200	125	1510	950	2300	1400
SCP4 150-315	30	1500	200	150	665	870	1745	1400
SCP4 150-315	37	1500	200	150	679	870	1790	1400
SCP4 150-315	45	1500	200	150	715	870	1820	1400
SCP4 150-315	55	1500	200	150	822	870	1885	1400
SCP4 150-315	75	1500	200	150	957	870	1960	1400
SCP4 150-450	45	1500	200	150	750	950	1820	1400
SCP4 150-450	55	1500	200	150	857	950	1885	1400
SCP4 150-450	75	1500	200	150	992	950	1960	1400
SCP4 150-450	90	1500	200	150	1097	950	2010	1400
SCP4 150-450	110	1500	200	150	1430	950	2190	1400
SCP4 150-450	132	1500	200	150	1530	950	2300	1400

SCP4

Horizontal, Double Suction, Split-Case Inline Pumps

Dimensions

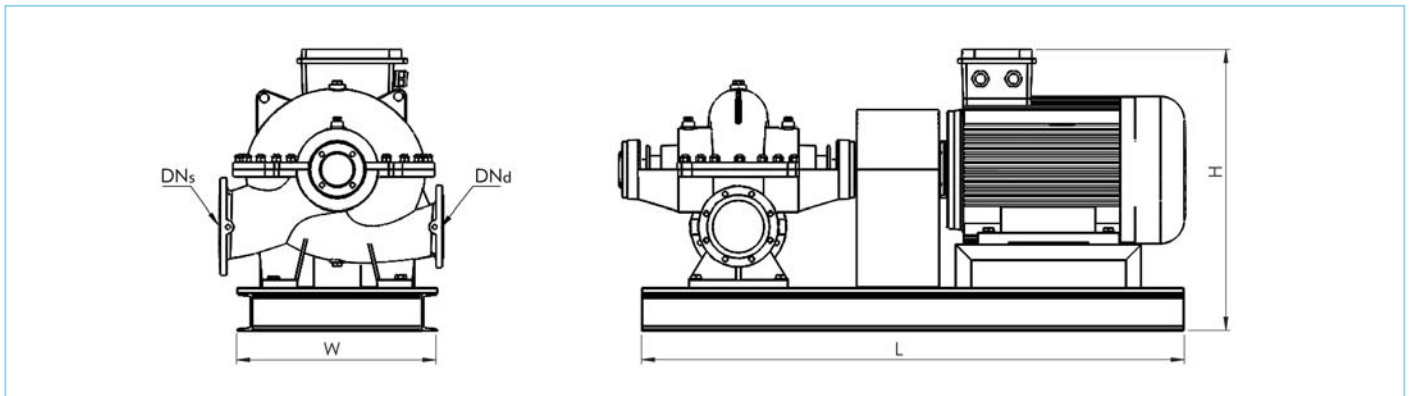

Model	kW	rpm	DN _s	DN _d	kg	w	l	h
SCP4 150-450	160	1500	200	150	1530	950	2300	1400
SCP4 150-450	185	1500	200	150	1530	950	2505	1400
SCP4 150-600	90	1500	250	150	1467	1050	2180	1400
SCP4 150-600	110	1500	250	150	1800	1050	2360	1400
SCP4 150-600	132	1500	250	150	1900	1050	2470	1400
SCP4 150-600	160	1500	250	150	1900	1050	2470	1400
SCP4 150-600	185	1500	250	150	1900	1050	2675	1400
SCP4 150-600	200	1500	250	150	2070	1050	2675	1400
SCP4 150-600	250	1500	250	150	2070	1050	3065	1400
SCP4 150-630	132	1500	250	150	1980	1050	2585	1400
SCP4 150-630	160	1500	250	150	1980	1050	2585	1400
SCP4 150-630	185	1500	250	150	1980	1050	2790	1400
SCP4 150-630	200	1500	250	150	2150	1050	2790	1400
SCP4 150-630	250	1500	250	150	2150	1050	3180	1400
SCP4 150-630	315	1500	250	150	2730	1050	3180	1400
SCP4 200-315	37	1500	250	200	854	950	1960	1400
SCP4 200-315	45	1500	250	200	890	950	1990	1400
SCP4 200-315	55	1500	250	200	997	950	2055	1400
SCP4 200-315	75	1500	250	200	1132	950	2130	1400
SCP4 200-315	90	1500	250	200	1237	950	2180	1400
SCP4 200-315	110	1500	250	200	1570	950	2360	1400
SCP4 200-400	75	1500	250	200	1137	950	2130	1400
SCP4 200-400	90	1500	250	200	1242	950	2180	1400
SCP4 200-400	110	1500	250	200	1575	950	2360	1400
SCP4 200-400	132	1500	250	200	1675	950	2470	1400
SCP4 200-400	160	1500	250	200	1675	950	2470	1400
SCP4 200-400	185	1500	250	200	1675	950	2675	1400
SCP4 200-400	200	1500	250	200	1845	950	2675	1400
SCP4 200-500	90	1500	250	200	1367	1050	2180	1400
SCP4 200-500	110	1500	250	200	1700	1050	2360	1400
SCP4 200-500	132	1500	250	200	1800	1050	2470	1400
SCP4 200-500	160	1500	250	200	1800	1050	2470	1400
SCP4 200-500	200	1500	250	200	1970	1050	2675	1400
SCP4 200-500	250	1500	250	200	1970	1050	3065	1400

SCP4

Horizontal, Double Suction, Split-Case Inline Pumps

Dimensions

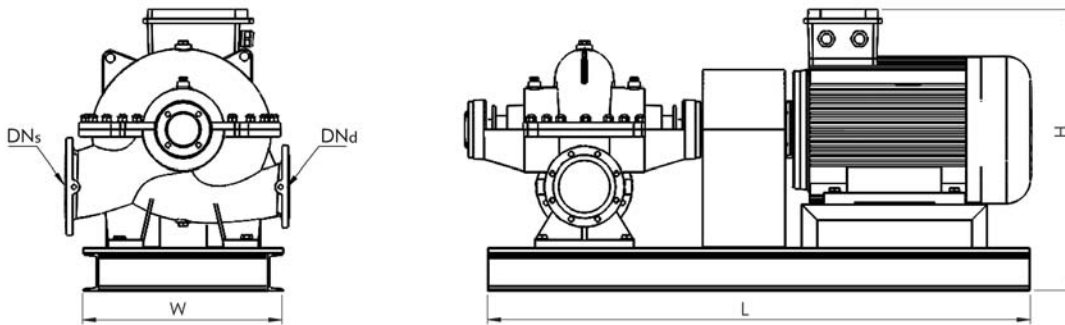

Model	kW	rpm	DN _s	DN _d	kg	w	l	h
SCP4 200-500	315	1500	250	200	2550	1050	3065	1400
SCP4 200-720	315	1500	300	200	3130	1250	3185	1400
SCP4 200-720	355	1500	300	200	4280	1250	3185	1400
SCP4 200-720	400	1500	300	200	4280	1250	3185	1400
SCP4 200-720	450	1500	300	200	4380	1250	3185	1400
SCP4 200-720	500	1500	300	200	4480	1250	3185	1400
SCP4 200-720	560	1500	300	200	4680	1250	3185	1400
SCP4 250-350	55	1500	300	250	1109	1100	2055	1400
SCP4 250-350	75	1500	300	250	1244	1100	2130	1400
SCP4 250-350	90	1500	300	250	1349	1100	2180	1400
SCP4 250-350	110	1500	300	250	1682	1100	2360	1400
SCP4 250-350	132	1500	300	250	1782	1100	2470	1400
SCP4 250-350	160	1500	300	250	1782	1100	2470	1400
SCP4 250-450	132	1500	300	250	1880	1100	2470	1400
SCP4 250-450	160	1500	300	250	1880	1100	2470	1400
SCP4 250-450	185	1500	300	250	1880	1100	2675	1400
SCP4 250-450	200	1500	300	250	2050	1100	2675	1400
SCP4 250-450	250	1500	300	250	2050	1100	3065	1400
SCP4 250-450	315	1500	300	250	2630	1100	3065	1400
SCP4 250-600	250	1500	300	250	2460	1200	3180	1400
SCP4 250-600	315	1500	300	250	3040	1200	3180	1400
SCP4 250-600	355	1500	300	250	4190	1200	3180	1400
SCP4 250-600	400	1500	300	250	4190	1200	3180	1400
SCP4 250-600	450	1500	300	250	4290	1200	3180	1400
SCP4 250-600	500	1500	300	250	4390	1200	3180	1400
SCP4 300-315	37	1500	350	300	984	1100	1960	1400
SCP4 300-315	45	1500	350	300	1020	1100	1990	1400
SCP4 300-315	55	1500	350	300	1127	1100	2055	1400
SCP4 300-315	75	1500	350	300	1262	1100	2130	1400
SCP4 300-315	90	1500	350	300	1367	1100	2180	1400
SCP4 300-315	110	1500	350	300	1700	1100	2360	1400
SCP4 300-400	45	1500	400	300	1445	1250	2230	1400
SCP4 300-400	55	1500	400	300	1552	1250	2295	1400
SCP4 300-400	75	1500	400	300	1687	1250	2370	1400

SCP4

Horizontal, Double Suction, Split-Case Inline Pumps

Dimensions

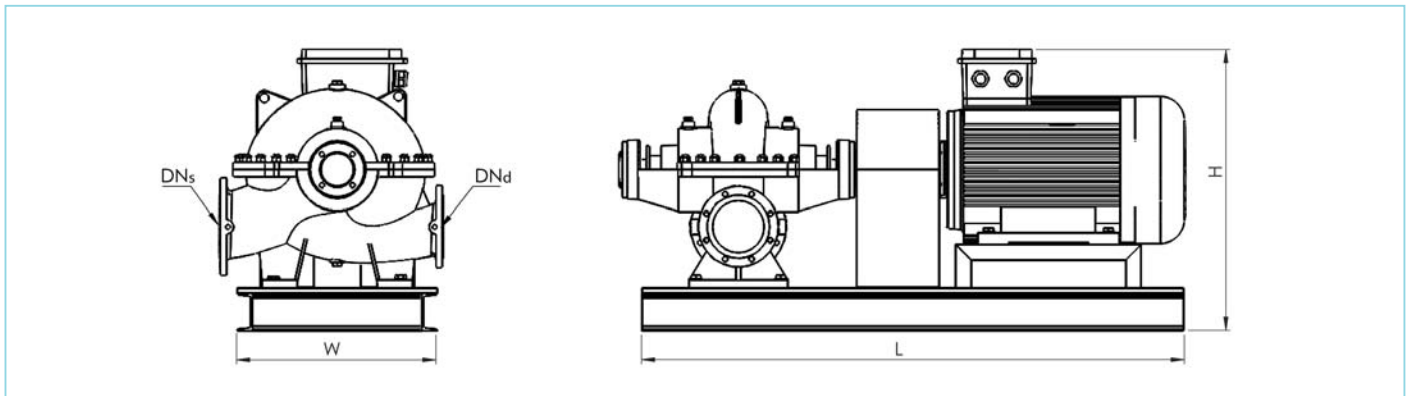

Model	kW	rpm	DN _s	DN _d	kg	w	l	h
SCP4 300-400	90	1500	400	300	1792	1250	2420	1400
SCP4 300-400	110	1500	400	300	2125	1250	2600	1400
SCP4 300-400	132	1500	400	300	2225	1250	2710	1400
SCP4 300-400	160	1500	400	300	2225	1250	2710	1400
SCP4 300-400	185	1500	400	300	2225	1250	2915	1400
SCP4 300-400	200	1500	400	300	2395	1250	2915	1400
SCP4 300-500	200	1500	400	300	2770	1450	2870	1400
SCP4 300-500	250	1500	400	300	2770	1450	3260	1400
SCP4 300-500	315	1500	400	300	3350	1450	3260	1400
SCP4 300-500	355	1500	400	300	1800	1450	3260	1400
SCP4 300-500	400	1500	400	300	4500	1450	3260	1400
SCP4 300-700	630	1500	400	300	5150	1550	3460	1400
SCP4 300-700	700	1500	400	300	5250	1550	3460	1400
SCP4 300-700	800	1500	400	300	5450	1550	3460	1400
SCP4 300-700	1000	1500	400	300	5650	1550	3460	1400
SCP4 300-700	1200	1500	400	300	5950	1550	3460	1400
SCP4 300-700	1400	1500	400	300	6150	1550	3460	1400
SCP4 350-350	75	1500	400	350	1662	1250	2370	1400
SCP4 350-350	90	1500	400	350	1767	1250	2420	1400
SCP4 350-350	110	1500	400	350	2100	1250	2600	1400
SCP4 350-350	132	1500	400	350	2200	1250	2710	1400
SCP4 350-350	160	1500	400	350	2200	1250	2710	1400
SCP4 350-350	185	1500	400	350	2200	1250	2915	1400
SCP4 350-400	160	1500	500	350	2500	1400	2710	1400
SCP4 350-400	185	1500	500	350	2500	1400	2915	1400
SCP4 350-400	200	1500	500	350	2670	1400	2915	1400
SCP4 350-400	250	1500	500	350	2670	1400	3305	1400
SCP4 350-400	315	1500	500	350	3250	1400	3305	1400
SCP4 350-400	355	1500	500	350	4400	1400	3305	1400
SCP4 350-400	400	1500	500	350	4400	1400	3305	1400
SCP4 350-500	200	1500	500	350	2705	1400	2870	1400
SCP4 350-500	250	1500	500	350	2705	1400	3260	1400
SCP4 350-500	315	1500	500	350	3285	1400	3260	1400
SCP4 350-500	355	1500	500	350	4435	1400	3260	1400

SCP4

Horizontal, Double Suction, Split-Case Inline Pumps

Dimensions

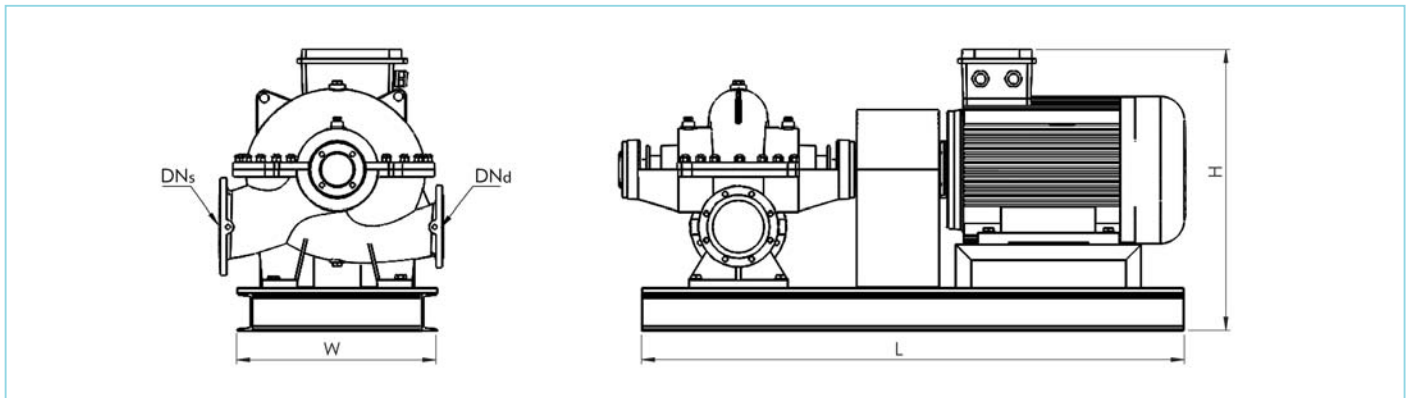

Model	kW	rpm	DN _s	DN _d	kg	w	l	h
SCP4 350-500	400	1500	500	350	4435	1400	3260	1400
SCP4 350-500	450	1500	500	350	4535	1400	3260	1400
SCP4 350-700	560	1500	500	350	5400	1600	3460	1400
SCP4 350-700	630	1500	500	350	5500	1600	3460	1400
SCP4 350-700	710	1500	500	350	5700	1600	3460	1400
SCP4 350-700	800	1500	500	350	5800	1600	3460	1400
SCP4 350-700	900	1500	500	350	5900	1600	3460	1400
SCP4 350-700	1000	1500	500	350	6000	1600	3460	1400
SCP4 350-700	1100	1500	500	350	6200	1600	3460	1400
SCP4 400-500	630	1500	500	400	5650	1230	3395	1400
SCP4 400-500	710	1500	500	400	5850	1230	3395	1400
SCP4 400-500	800	1500	500	400	5950	1230	3395	1400
SCP4 400-500	900	1500	500	400	6050	1230	3395	1400
SCP4 400-500	1000	1500	500	400	6150	1230	3395	1400
SCP4 400-630	710	1500	500	400	5600	1450	3480	1400
SCP4 400-630	800	1500	500	400	5700	1450	3480	1400
SCP4 400-630	900	1500	500	400	5800	1450	3480	1400
SCP4 400-630	1000	1500	500	400	5900	1450	3480	1400
SCP4 400-630	1100	1500	500	400	6100	1450	3480	1400
SCP4 400-630	1400	1500	500	400	6400	1450	3480	1400

SCP6

Horizontal, Double Suction, Split-Case Inline Pumps

Dimensions

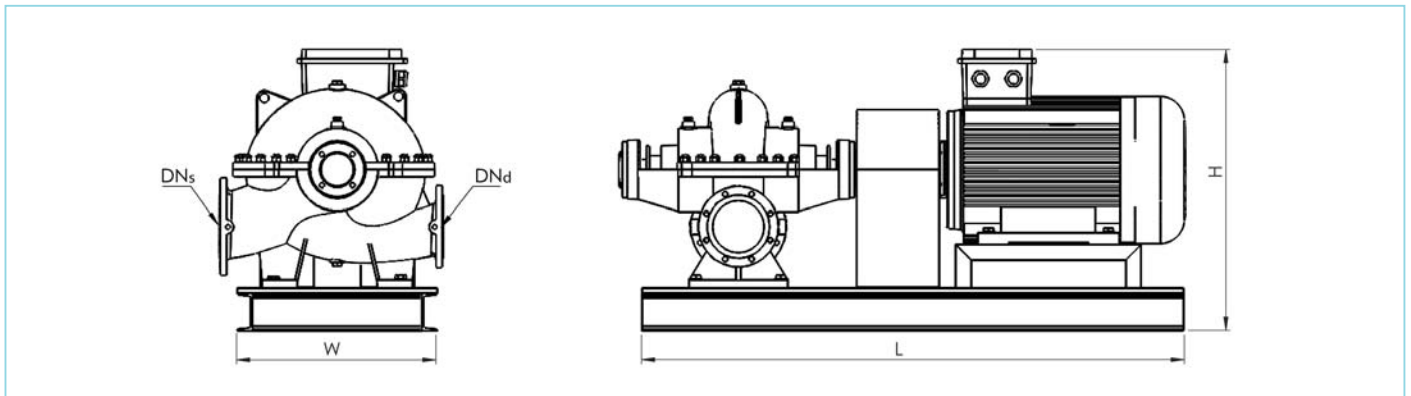

Model	kW	rpm	DN _s	DN _d	kg	w	l	h
SCP6 65-250	2,2	1000	100	65	284	600	1325	1400
SCP6 65-250	3	1000	100	65	284	600	1325	1400
SCP6 65-250	4	1000	100	65	284	600	1325	1400
SCP6 65-250	5,5	1000	100	65	284	600	1325	1400
SCP6 80-200	0,75	1000	125	80	284	600	1325	1400
SCP6 80-200	1,1	1000	125	80	284	600	1325	1400
SCP6 80-200	1,5	1000	125	80	284	600	1325	1400
SCP6 80-200	2,2	1000	125	80	284	600	1325	1400
SCP6 80-250	1,5	1000	125	80	294	600	1325	1400
SCP6 80-250	2,2	1000	125	80	294	600	1325	1400
SCP6 80-250	3	1000	125	80	294	600	1325	1400
SCP6 80-250	4	1000	125	80	294	600	1325	1400
SCP6 80-315	3	1000	125	80	316	660	1325	1400
SCP6 80-315	4	1000	125	80	316	660	1325	1400
SCP6 80-315	5,5	1000	125	80	316	660	1325	1400
SCP6 80-315	7,5	1000	125	80	316	660	1325	1400
SCP6 100-250	2,2	1000	150	100	339	670	1415	1400
SCP6 100-250	3	1000	150	100	339	670	1415	1400
SCP6 100-250	4	1000	150	100	339	670	1415	1400
SCP6 100-250	5,5	1000	150	100	339	670	1415	1400
SCP6 100-250	7,5	1000	150	100	339	670	1415	1400
SCP6 100-315	2,2	1000	150	100	349	670	1415	1400
SCP6 100-315	3	1000	150	100	349	670	1415	1400
SCP6 100-315	4	1000	150	100	349	670	1415	1400
SCP6 100-315	5,5	1000	150	100	349	670	1415	1400
SCP6 100-315	7,5	1000	150	100	349	670	1415	1400
SCP6 100-400	5,5	1000	150	100	409	790	1415	1400
SCP6 100-400	7,5	1000	150	100	409	790	1415	1400
SCP6 100-400	11	1000	150	100	437	790	1415	1400
SCP6 100-400	15	1000	150	100	485	790	1470	1400
SCP6 125-315	4	1000	200	125	449	790	1590	1400

SCP6

Horizontal, Double Suction, Split-Case Inline Pumps

Dimensions

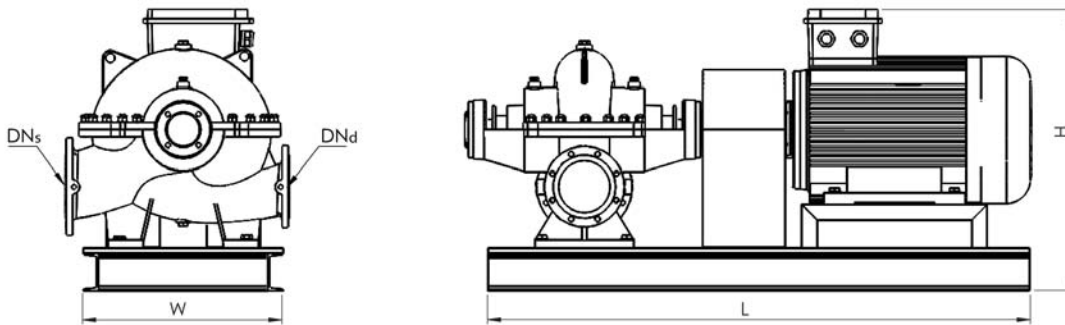

Model	kW	rpm	DNs	DNd	kg	w	l	h
SCP6 125-315	5,5	1000	200	125	449	790	1590	1400
SCP6 125-315	7,5	1000	200	125	449	790	1590	1400
SCP6 125-315	11	1000	200	125	477	790	1590	1400
SCP6 125-350	7,5	1000	200	125	499	920	1590	1400
SCP6 125-350	11	1000	200	125	527	920	1590	1400
SCP6 125-350	15	1000	200	125	575	920	1645	1400
SCP6 125-350	18,5	1000	200	125	600	920	1675	1400
SCP6 125-450	11	1000	200	125	557	950	1590	1400
SCP6 125-450	15	1000	200	125	605	950	1645	1400
SCP6 125-450	18,5	1000	200	125	630	950	1675	1400
SCP6 125-450	22	1000	200	125	660	950	1715	1400
SCP6 125-450	30	1000	200	125	702	950	1745	1400
SCP6 125-450	37	1000	200	125	818	950	1790	1400
SCP6 150-315	7,5	1000	200	150	514	870	1590	1400
SCP6 150-315	11	1000	200	150	542	870	1590	1400
SCP6 150-315	15	1000	200	150	590	870	1645	1400
SCP6 150-315	18,5	1000	200	150	615	870	1675	1400
SCP6 150-315	22	1000	200	150	645	870	1715	1400
SCP6 150-450	15	1000	200	150	625	950	1645	1400
SCP6 150-450	18,5	1000	200	150	650	950	1675	1400
SCP6 150-450	22	1000	200	150	680	950	1715	1400
SCP6 150-450	30	1000	200	150	722	950	1745	1400
SCP6 150-450	37	1000	200	150	838	950	1790	1400
SCP6 150-450	45	1000	200	150	966	950	1820	1400
SCP6 150-550	18,5	1000	200	150	1045	1030	1935	1400
SCP6 150-550	22	1000	200	150	1075	1030	1975	1400
SCP6 150-550	30	1000	200	150	1117	1030	2005	1400
SCP6 150-550	37	1000	200	150	1233	1030	2050	1400
SCP6 150-550	45	1000	200	150	1361	1030	2080	1400
SCP6 150-550	55	1000	200	150	1420	1030	2145	1400
SCP6 150-550	75	1000	200	150	1815	1030	2220	1400

SCP6

Horizontal, Double Suction, Split-Case Inline Pumps

Dimensions

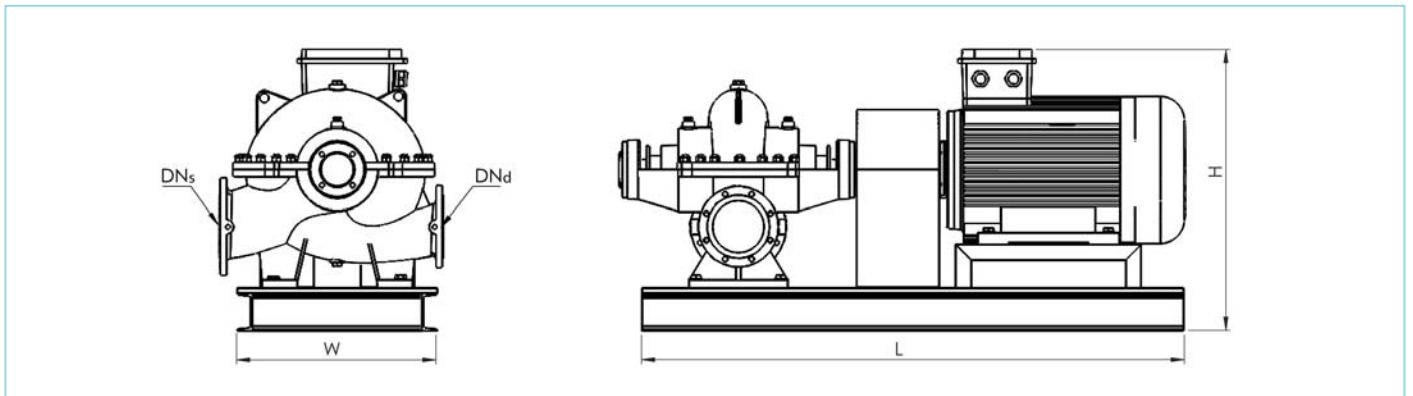

Model	kW	rpm	DN _s	DN _d	kg	w	l	h
SCP6 150-600	18,5	1000	250	150	1020	1050	1845	1400
SCP6 150-600	22	1000	250	150	1050	1050	1885	1400
SCP6 150-600	30	1000	250	150	1092	1050	1915	1400
SCP6 150-600	37	1000	250	150	1208	1050	1960	1400
SCP6 150-600	45	1000	250	150	1336	1050	1990	1400
SCP6 150-600	55	1000	250	150	1395	1050	2055	1400
SCP6 150-600	75	1000	250	150	1790	1050	2130	1400
SCP6 150-600	90	1000	250	150	1880	1050	2180	1400
SCP6 200-315	7,5	1000	250	200	689	950	1760	1400
SCP6 200-315	11	1000	250	200	717	950	1760	1400
SCP6 200-315	15	1000	250	200	765	950	1815	1400
SCP6 200-315	18,5	1000	250	200	790	950	1845	1400
SCP6 200-400	18,5	1000	250	200	795	950	1845	1400
SCP6 200-400	22	1000	250	200	825	950	1885	1400
SCP6 200-400	30	1000	250	200	867	950	1915	1400
SCP6 200-400	37	1000	250	200	983	950	1960	1400
SCP6 200-400	45	1000	250	200	1111	950	1990	1400
SCP6 200-500	22	1000	250	200	950	1050	1885	1400
SCP6 200-500	3	1000	250	200	819	1050	1760	1400
SCP6 200-500	37	1000	250	200	1108	1050	1960	1400
SCP6 200-500	45	1000	250	200	1236	1050	1990	1400
SCP6 200-500	55	1000	250	200	1295	1050	2055	1400
SCP6 200-500	75	1000	250	200	1690	1050	2130	1400
SCP6 200-500	90	1000	250	200	1780	1050	2180	1400
SCP6 200-720	18,5	1000	300	200	1500	1250	1890	1400
SCP6 200-720	22	1000	300	200	1530	1250	1930	1400
SCP6 200-720	30	1000	300	200	1572	1250	1960	1400
SCP6 200-720	37	1000	300	200	1688	1250	2005	1400
SCP6 200-720	45	1000	300	200	1816	1250	2035	1400
SCP6 200-720	55	1000	300	200	1875	1250	2100	1400
SCP6 200-720	75	1000	300	200	2270	1250	2175	1400

SCP6

Horizontal, Double Suction, Split-Case Inline Pumps

Dimensions

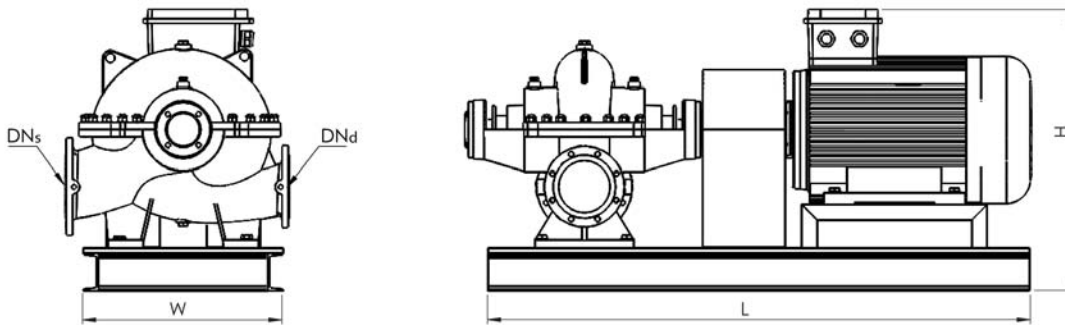

Model	kW	rpm	DN _s	DN _d	kg	w	l	h
SCP6 200-720	90	1000	300	200	2360	1250	2225	1400
SCP6 250-350	22	1000	300	250	932	1100	1885	1400
SCP6 250-350	30	1000	300	250	974	1100	1915	1400
SCP6 250-350	37	1000	300	250	1090	1100	1960	1400
SCP6 250-350	45	1000	300	250	1218	1100	1990	1400
SCP6 250-450	37	1000	300	250	1188	1100	1960	1400
SCP6 250-450	45	1000	300	250	1316	1100	1990	1400
SCP6 250-450	55	1000	300	250	1375	1100	2055	1400
SCP6 250-450	75	1000	300	250	1770	1100	2130	1400
SCP6 250-450	90	1000	300	250	1860	1100	2180	1400
SCP6 250-600	55	1000	300	250	1785	1200	2170	1400
SCP6 250-600	75	1000	300	250	2180	1200	2245	1400
SCP6 250-600	90	1000	300	250	2270	1200	2295	1400
SCP6 250-600	110	1000	300	250	2340	1200	2475	1400
SCP6 250-600	132	1000	300	250	2400	1200	2585	1400
SCP6 250-600	160	1000	300	250	2790	1200	2585	1400
SCP6 250-600	185	1000	300	250	2790	1200	2790	1400
SCP6 300-315	11	1000	350	300	847	1100	1760	1400
SCP6 300-315	15	1000	350	300	895	1100	1815	1400
SCP6 300-315	18,5	1000	350	300	920	1100	1845	1400
SCP6 300-315	22	1000	350	300	950	1100	1885	1400
SCP6 300-400	30	1000	400	300	1417	1250	2155	1400
SCP6 300-400	37	1000	400	300	1533	1250	2200	1400
SCP6 300-400	45	1000	400	300	1661	1250	2230	1400
SCP6 300-400	55	1000	400	300	1720	1250	2295	1400
SCP6 300-400	75	1000	400	300	2115	1250	2370	1400
SCP6 300-500	45	1000	400	300	2036	1450	2185	1400
SCP6 300-500	55	1000	400	300	2095	1450	2250	1400
SCP6 300-500	75	1000	400	300	2490	1450	2325	1400
SCP6 300-500	90	1000	400	300	2580	1450	2375	1400
SCP6 300-500	110	1000	400	300	2650	1450	2555	1400

SCP6

Horizontal, Double Suction, Split-Case Inline Pumps

Dimensions

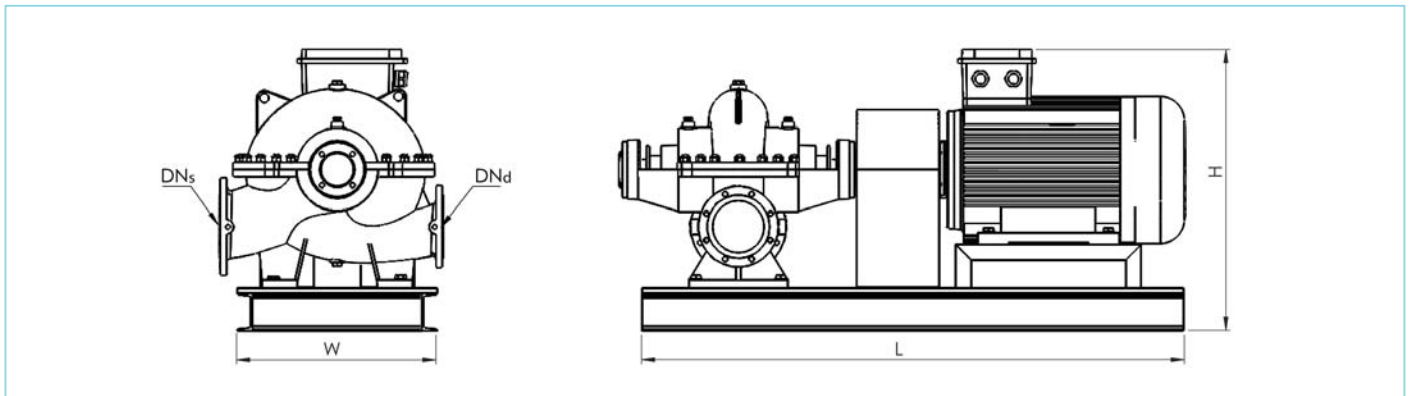

Model	kW	rpm	DN _s	DN _d	kg	w	l	h
SCP6 300-500	132	1000	400	300	2710	1450	2665	1400
SCP6 300-500	160	1000	400	300	3100	1450	2665	1400
SCP6 300-500	185	1000	400	300	3100	1450	2870	1400
SCP6 300-700	75	1000	400	300	2640	1550	2525	1400
SCP6 300-700	90	1000	400	300	2730	1550	2575	1400
SCP6 300-700	110	1000	400	300	2800	1550	2755	1400
SCP6 300-700	132	1000	400	300	2860	1550	2865	1400
SCP6 300-700	160	1000	400	300	3250	1550	2865	1400
SCP6 300-700	185	1000	400	300	3250	1550	3070	1400
SCP6 300-700	200	1000	400	300	3350	1550	3070	1400
SCP6 300-700	250	1000	400	300	3350	1550	3460	1400
SCP6 350-350	22	1000	400	350	1350	1250	2125	1400
SCP6 350-350	30	1000	400	350	1392	1250	2155	1400
SCP6 350-350	37	1000	400	350	1508	1250	2200	1400
SCP6 350-350	45	1000	400	350	1636	1250	2230	1400
SCP6 350-350	55	1000	400	350	1695	1250	2295	1400
SCP6 350-400	45	1000	500	350	1936	1400	2230	1400
SCP6 350-400	55	1000	500	350	1995	1400	2295	1400
SCP6 350-400	75	1000	500	350	2390	1400	2370	1400
SCP6 350-400	90	1000	500	350	2480	1400	2420	1400
SCP6 350-400	110	1000	500	350	2550	1400	2600	1400
SCP6 350-500	90	1000	500	350	2515	1400	2375	1400
SCP6 350-500	110	1000	500	350	2585	1400	2555	1400
SCP6 350-500	132	1000	500	350	2645	1400	2665	1400
SCP6 350-500	160	1000	500	350	3035	1400	2665	1400
SCP6 350-500	185	1000	500	350	3035	1400	2870	1400
SCP6 350-700	185	1000	500	350	3600	1600	3070	1400
SCP6 350-700	200	1000	500	350	3700	1600	3070	1400
SCP6 350-700	250	1000	500	350	3700	1600	3460	1400
SCP6 350-700	315	1000	500	350	5100	1600	3460	1400
SCP6 350-700	355	1000	500	350	5200	1600	3460	1400

SCP6

Horizontal, Double Suction, Split-Case Inline Pumps

Dimensions

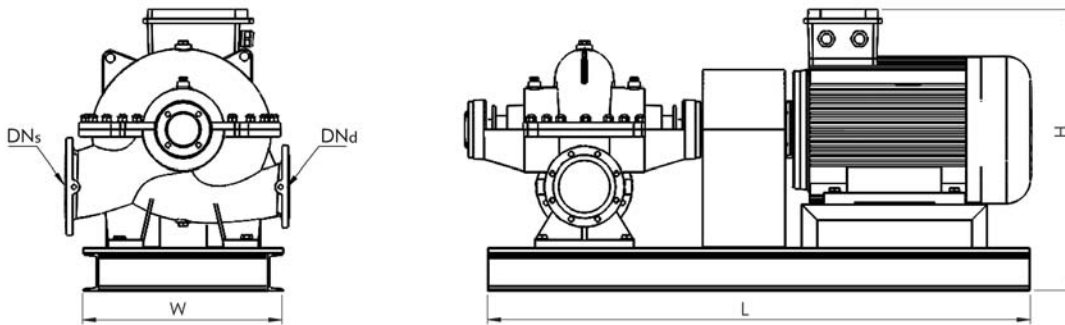

Model	kW	rpm	DN _s	DN _d	kg	w	l	h
SCP6 350-700	400	1000	500	350	5400	1600	3460	1400
SCP6 400-500	160	1000	500	400	3750	1550	2800	1400
SCP6 400-500	185	1000	500	400	3750	1550	3005	1400
SCP6 400-500	200	1000	500	400	3850	1550	3005	1400
SCP6 400-500	250	1000	500	400	3850	1550	3395	1400
SCP6 400-500	315	1000	500	400	5250	1550	3395	1400
SCP6 400-600	160	1000	500	400	4660	1550	3145	1400
SCP6 400-600	185	1000	500	400	4660	1550	3350	1400
SCP6 400-600	200	1000	500	400	4760	1550	3350	1400
SCP6 400-600	250	1000	500	400	4760	1550	3740	1400
SCP6 400-600	315	1000	500	400	6160	1550	3740	1400
SCP6 400-630	200	1000	500	400	3600	1450	3090	1400
SCP6 400-630	250	1000	500	400	3600	1450	3480	1400
SCP6 400-630	315	1000	500	400	5000	1450	3480	1400
SCP6 400-630	355	1000	500	400	5100	1450	3480	1400
SCP6 400-630	400	1000	500	400	5300	1450	3480	1400
SCP6 500-540	132	1000	600	500	3470	1455	3000	1410
SCP6 500-540	160	1000	600	500	3860	1455	1675	1410
SCP6 500-540	185	1000	600	500	3860	1455	3205	1410
SCP6 500-540	200	1000	600	500	3960	1455	3205	1410
SCP6 500-620	250	1000	600	500	5280	1900	3815	1600
SCP6 500-620	315	1000	600	500	6680	1900	3815	1600
SCP6 500-620	355	1000	600	500	6780	1900	3815	1600
SCP6 500-620	400	1000	600	500	6980	1900	3815	1600
SCP6 500-650	250	1000	600	500	6500	2100	3895	1540
SCP6 500-650	315	1000	600	500	7900	2100	3895	1540
SCP6 500-650	355	1000	600	500	8000	2100	3895	1540
SCP6 500-650	400	1000	600	500	8200	2100	3895	1540
SCP6 500-650	450	1000	600	500	8300	2100	3895	1540
SCP6 500-650	500	1000	600	500	8400	2100	3895	1540
SCP6 500-800	315	1000	600	500	6900	1710	3760	1520

SCP6

Horizontal, Double Suction, Split-Case Inline Pumps

Dimensions

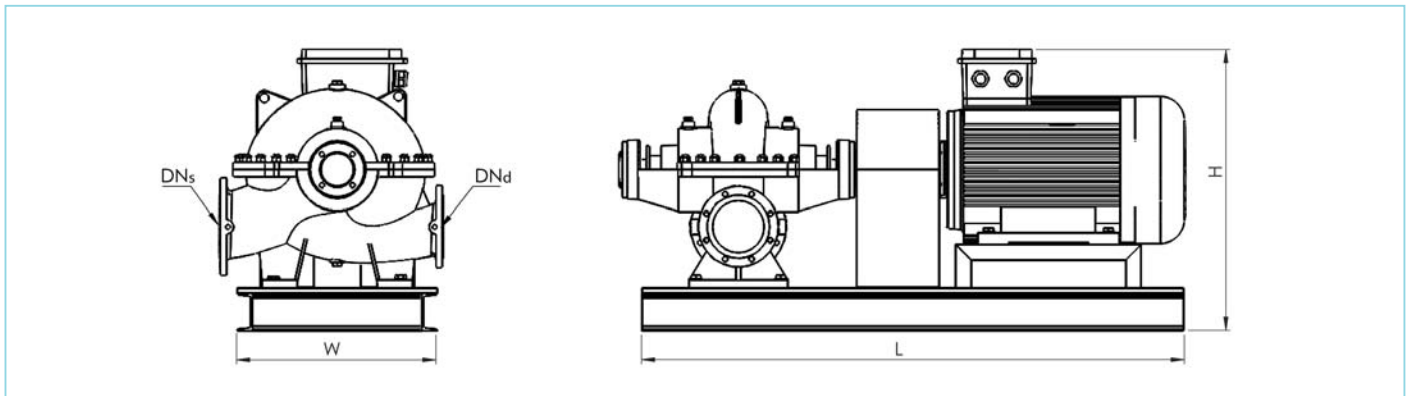

Model	kW	rpm	DN _s	DN _d	kg	w	l	h
SCP6 500-800	355	1000	600	500	7000	1710	3760	1520
SCP6 500-800	400	1000	600	500	7200	1710	3760	1520
SCP6 500-800	450	1000	600	500	7300	1710	3760	1520
SCP6 500-800	500	1000	600	500	7400	1710	3760	1520
SCP6 500-800	560	1000	600	500	7500	1710	3760	1520
SCP6 500-800	630	1000	600	500	7600	1710	3760	1520
SCP6 500-800	710	1000	600	500	7700	1710	3760	1520
SCP6 500-900	450	1000	600	500	7300	1710	3760	1520
SCP6 500-900	500	1000	600	500	7400	1710	3760	1520
SCP6 500-900	560	1000	600	500	7500	1710	3760	1520
SCP6 500-900	630	1000	600	500	7600	1710	3760	1520
SCP6 500-900	710	1000	600	500	7700	1710	3760	1520
SCP6 500-900	800	1000	600	500	7800	1710	3760	1520
SCP6 600-800	500	1000	700	600	8550	1750	3640	1940
SCP6 600-800	560	1000	700	600	8650	1750	3640	1940
SCP6 600-800	630	1000	700	600	8750	1750	3640	1940
SCP6 600-800	710	1000	700	600	8850	1750	3640	1940
SCP6 600-800	800	1000	700	600	8950	1750	3640	1940
SCP6 600-800	900	1000	700	600	9050	1750	3640	1940
SCP6 600-800	1100	1000	700	600	9150	1750	3640	1940
SCP6 700-700	630	1000	800	700	10435	2200	3860	2550
SCP6 700-700	710	1000	800	700	10535	2200	3860	2550
SCP6 700-700	800	1000	800	700	10635	2200	3860	2550
SCP6 700-700	900	1000	800	700	10735	2200	3860	2550
SCP6 700-700	1100	1000	800	700	10835	2200	3860	2550
SCP6 700-700	1200	1000	800	700	10935	2200	3860	2550
SCP6 700-700	1300	1000	800	700	11035	2200	3860	2550
SCP6 700-710	900	1000	800	700	10640	2300	4470	2010
SCP6 700-710	1100	1000	800	700	10740	2300	4470	2010
SCP6 700-710	1200	1000	800	700	10840	2300	4470	2010
SCP6 700-710	1300	1000	800	700	10940	2300	4470	2010
SCP6 700-710	1400	1000	800	700	11140	2300	4470	2010
SCP6 700-710	1500	1000	800	700	11140	2300	4470	2010