



Construction

This macerating pumping system has been designed to pump away the waste water from WC, washbasin, bidet and shower. It is possible to install a complete bathroom in a basement conversion or loft extension.

The GEOCOMP macerating system is installed in a case specifically designed for horizontal outlet spigots. Installed and used correctly, this unit will give consistent and reliable service.

The system has a grinder pump, clapet valve and carbon filter. GEOCOMP is provided with flexible sleeves, elbow, metal hose clips.

Operating conditions

Voltage: 220-240 V

Frequency: 50 Hz

Degree of protection: IP44

Maximum power rating: 550 W

Maximum current consumption: 2,5 A

Vertical pumping: max. 4 m

Liquid temperature up to 35 °C

Application

GEOCOMP takes waste from :



WC



Washbasin



Bidet



Tub



Shower

Characteristic curve

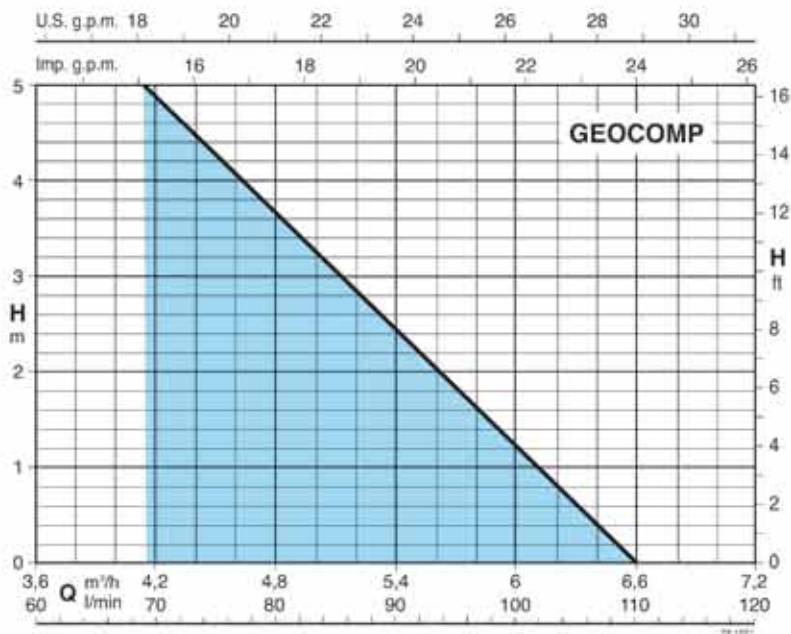

Q	m ³ /h	4,14	4,2	4,8	5,4	6	6,6
	l/min	69	70	80	90	100	110
H	m	5	4,89	3,66	2,42	1,24	0

Installation

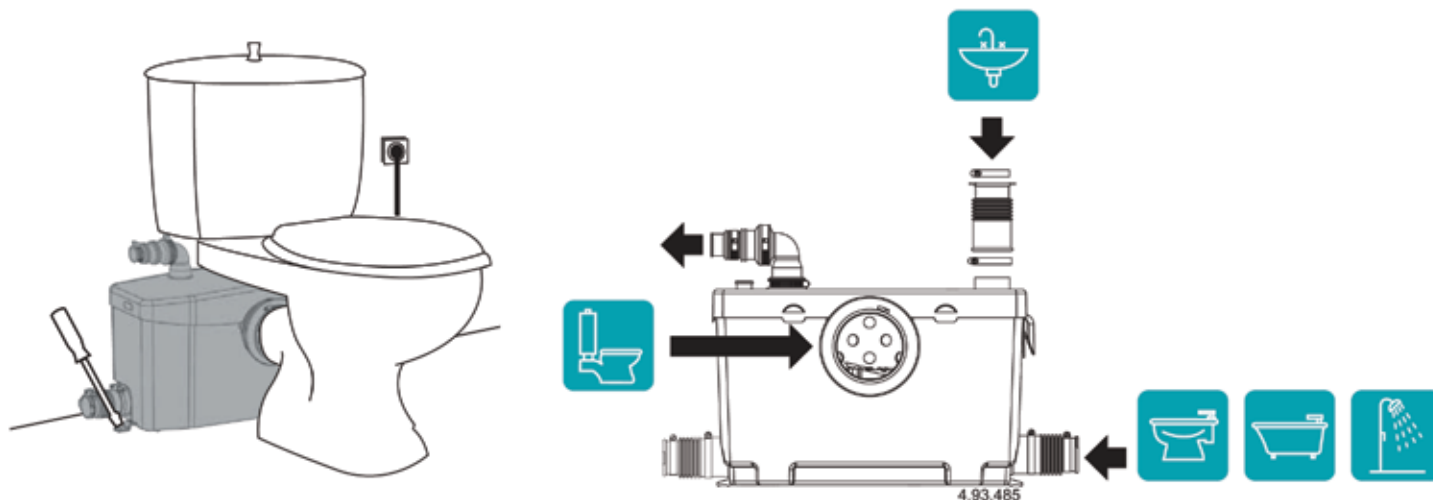

Performance

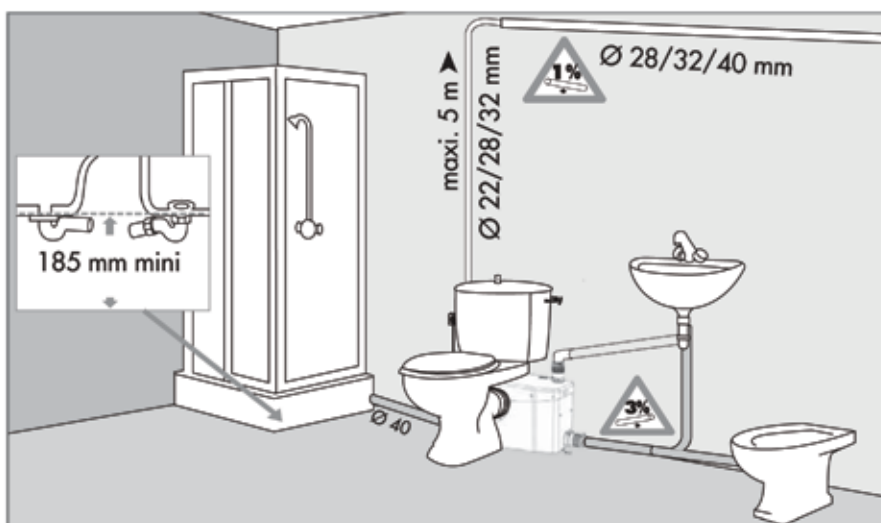
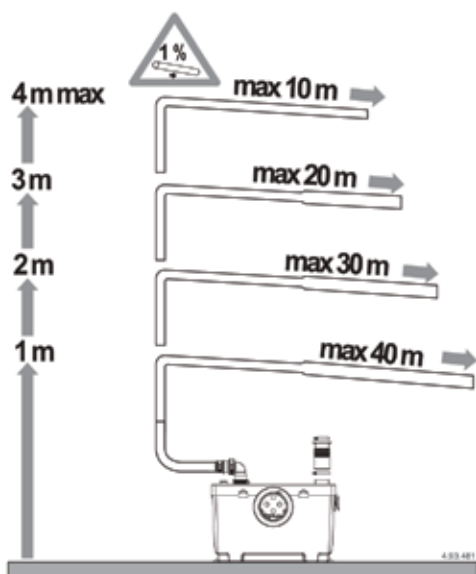

Dimensions and weight

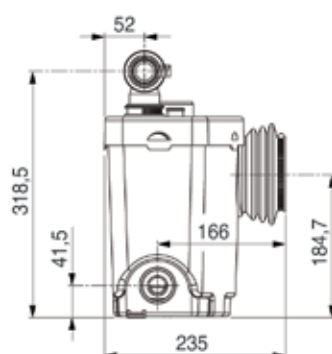
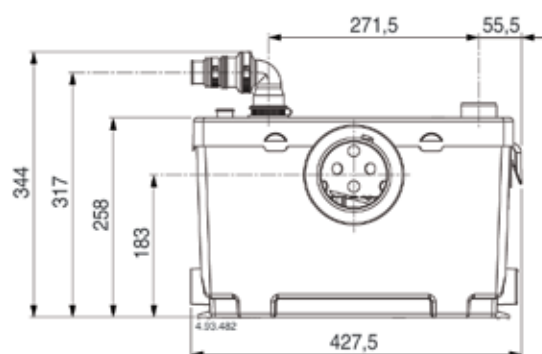

weight: kg 6,8